

PLAN- BENDS

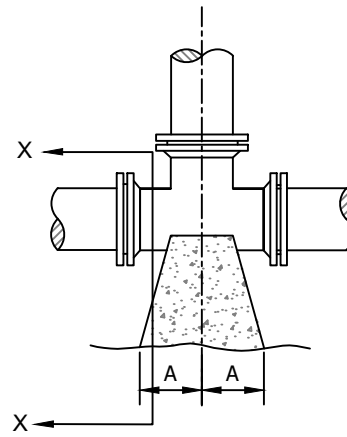

PLAN -TEES

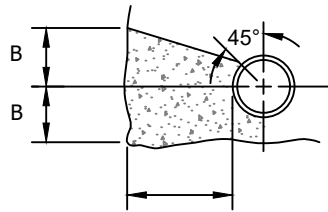

18" MIN.-10" DIA. OR LESS  
24" MIN.-12" DIA. OR GREATER

SECTION X-X  
BENDS & TEES

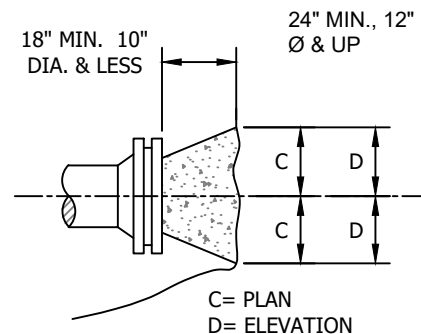

PLAN & ELEVATION  
PLUGS

PIPE SIZE	90° BEND		45° BEND		22-1/2° BEND		11-1/4° BEND		TEE		PLUG	
	A	B	A	B	A	B	A	B	A	B	C	D
4"	18"	12"	10"	13"	7"	10"	7"	10"	12"	14"	13"	6"
6"	18"	12"	10"	13"	7"	10"	7"	10"	12"	14"	19"	9"
8"	24"	18"	13"	18"	10"	12"	10"	12"	16"	18"	25"	11"
10"	28"	22"	15"	22"	12"	15"	12"	15"	20"	22"	31"	14"
12"	32"	28"	19"	28"	14"	18"	14"	18"	22"	28"	37"	17"
16"	54"	38"	30"	36"	18"	36"	18"	36"	36"	42"	54"	24"

2000 PSF SOIL (SAND & GRAVEL WITH CLAY)

NOTES:

1. BASED ON 200 PSI STATIC PRESSURE PLUS AWWA WATER HAMMER ALLOWANCE.
2. ALL BEARING SURFACES TO BE CARRIED TO UNDISTURBED GROUND.
3. THRUST BLOCKS TO BE USED AT ALL LINES OPERATING UNDER PRESSURE.
4. KEEP ALL PIPING JOINTS CLEAR OF CONCRETE THRUST BLOCKS.
5. WRAP ALL FITTINGS IN PLASTIC.



BRUNSWICK REGIONAL  
WATER AND SEWER H2GO

EFFECTIVE: APRIL 2022

# THRUST BLOCKING

STD. NO.

1000.01

NOT TO SCALE

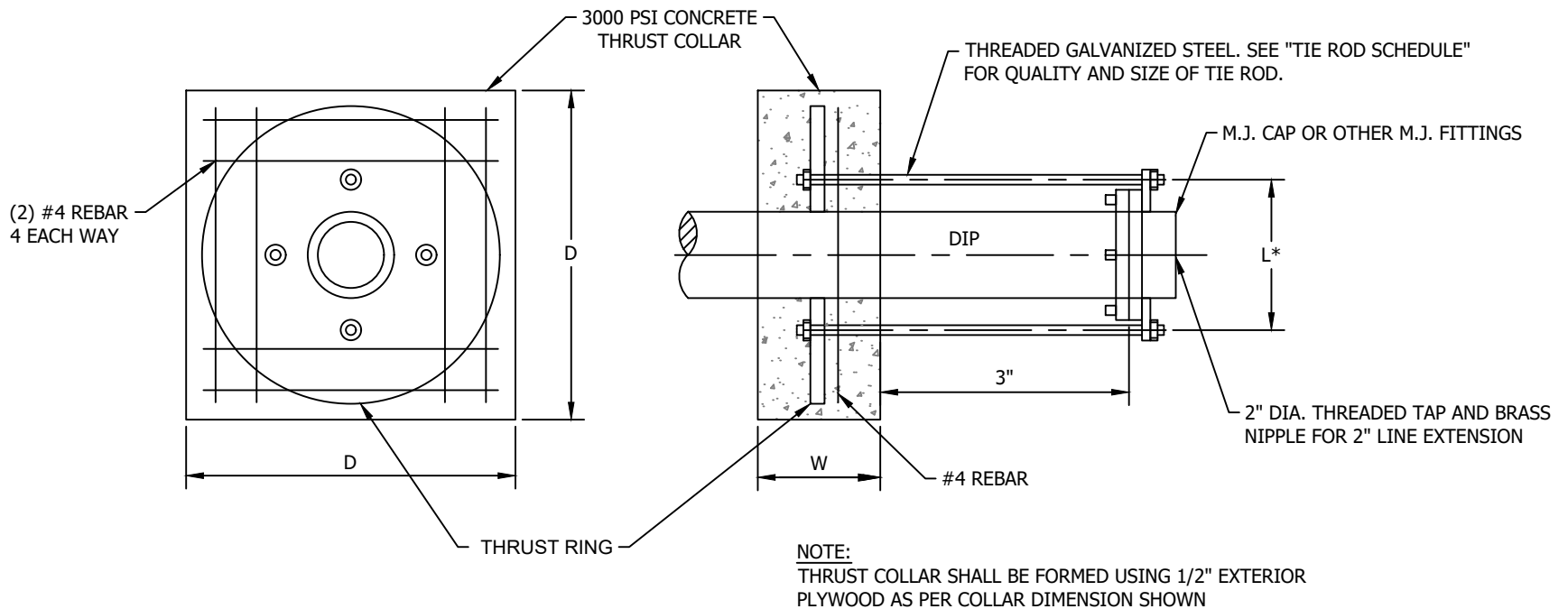

TIE ROD SCHEDULE		
PIPE DIAM.	QUAN.	SIZE
0'-4"	2	0'-0 5/8"
0'-6"	2	0'-0 3/4"
0'-8"	2	0'-0 3/4"
1'-0"	4	0'-0 3/4"
1'-4"	4	0'-0 7/8"
1'-8"	4	0'-1"
2'-0"	4	0'-1 1/4"
2'-6"	4	0'-1 1/2"

COLLAR DIMENSIONS			
SIZE LINE	MIN. W	MIN. D	PLATE DIAM.
0'-4"	0'-6"	L+8"	L+2"
0'-6"	0'-9"	L+9"	L+3"
0'-8"	1'-0"	L+9"	L+3"
1'-0"	1'-6"	L+9"	L+3"
1'-4"	1'-6"	L+9"	L+3"
1'-8"	20"?	L+9"	L+3"
2'-0"	24"?	L+10"	L+4"
2'-6"	2'-0"	L+11"	L+5"

\* CONTRACTOR VERIFY DISTANCE W/COLLAR SUPPLIERS.



BRUNSWICK REGIONAL  
WATER AND SEWER H2GO

EFFECTIVE: APRIL 2022

# THRUST COLLAR

STD. NO.

1000.02

NOT TO SCALE



START LAYING AT LOW END AND BUILD AGAINST DIRECTION OF FLOW

BRING STONE TO SPRINGLINE (MIDDLE OF PVC)

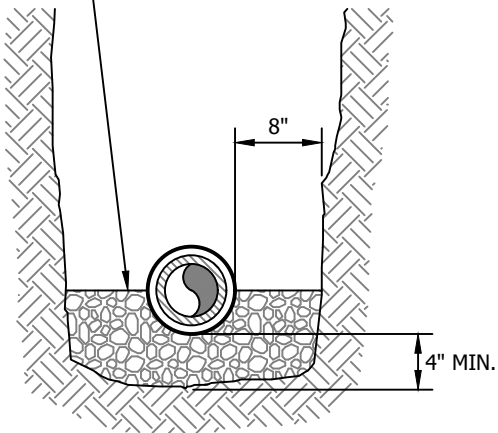

P.V.C. PIPE  
NORMAL CONDITIONS

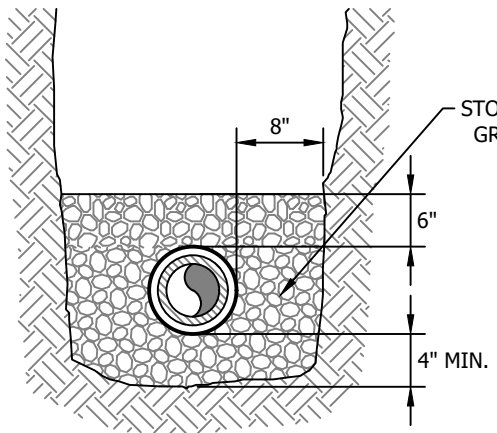

P.V.C. PIPE  
WET CONDITIONS

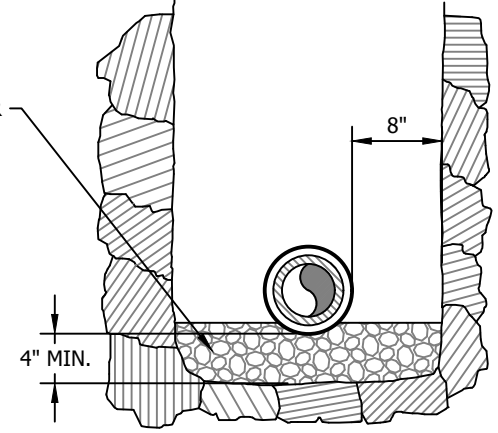

D.I.P. IN ROCK  
WET CONDITIONS



BRUNSWICK REGIONAL  
WATER AND SEWER H2GO  
EFFECTIVE: APRIL 2022

STANDARD TRENCHING DETAIL  
(GRAVITY SEWER)

STD. NO.  
1000.03  
NOT TO SCALE

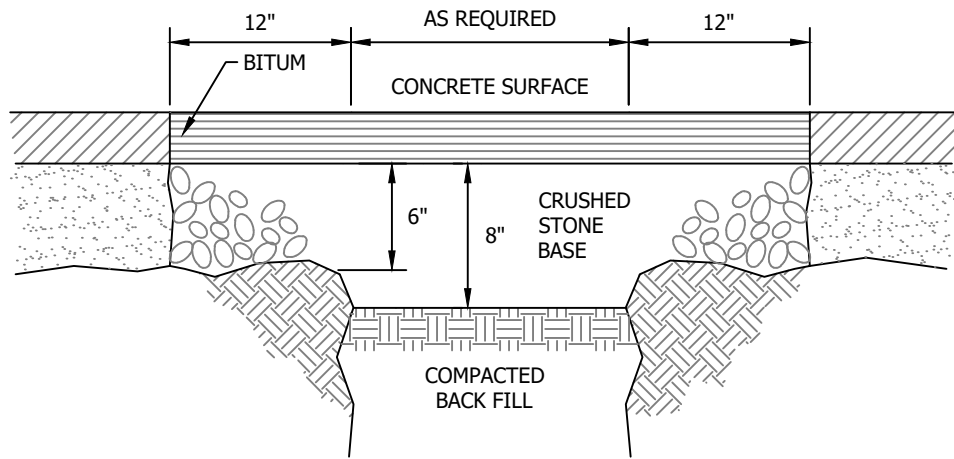

USE MATERIALS PER NCDOT REQUIREMENTS ON NCDOT DRIVEWAYS AND ROADWAYS.



BRUNSWICK REGIONAL  
WATER AND SEWER H2GO

EFFECTIVE: APRIL 2022

## PAVEMENT REPAIR

STD. NO.

1000.04

NOT TO SCALE



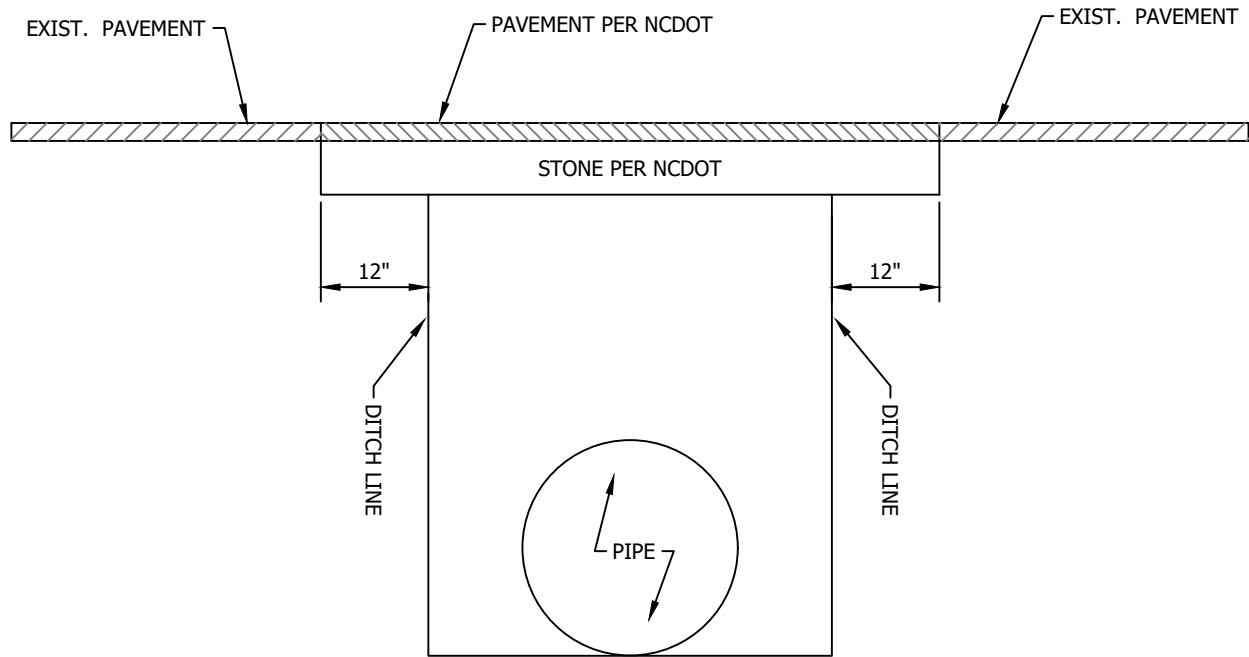

**NOTES:**

1. REFERENCE SPECIFICATIONS FOR BACKFILLING AND COMPACTION REQUIREMENTS.
2. CUT-BACK TO BE PERFORMED AFTER TRENCH BACKFILLING AND COMPACTION.
3. NEW PAVEMENT TO MEET ALL NCDOT REQUIREMENTS.



BRUNSWICK REGIONAL  
WATER AND SEWER H2GO

EFFECTIVE: APRIL 2022

# PIPE INSTALLATION PAVEMENT REPAIR

STD. NO.

1000.05

NOT TO SCALE

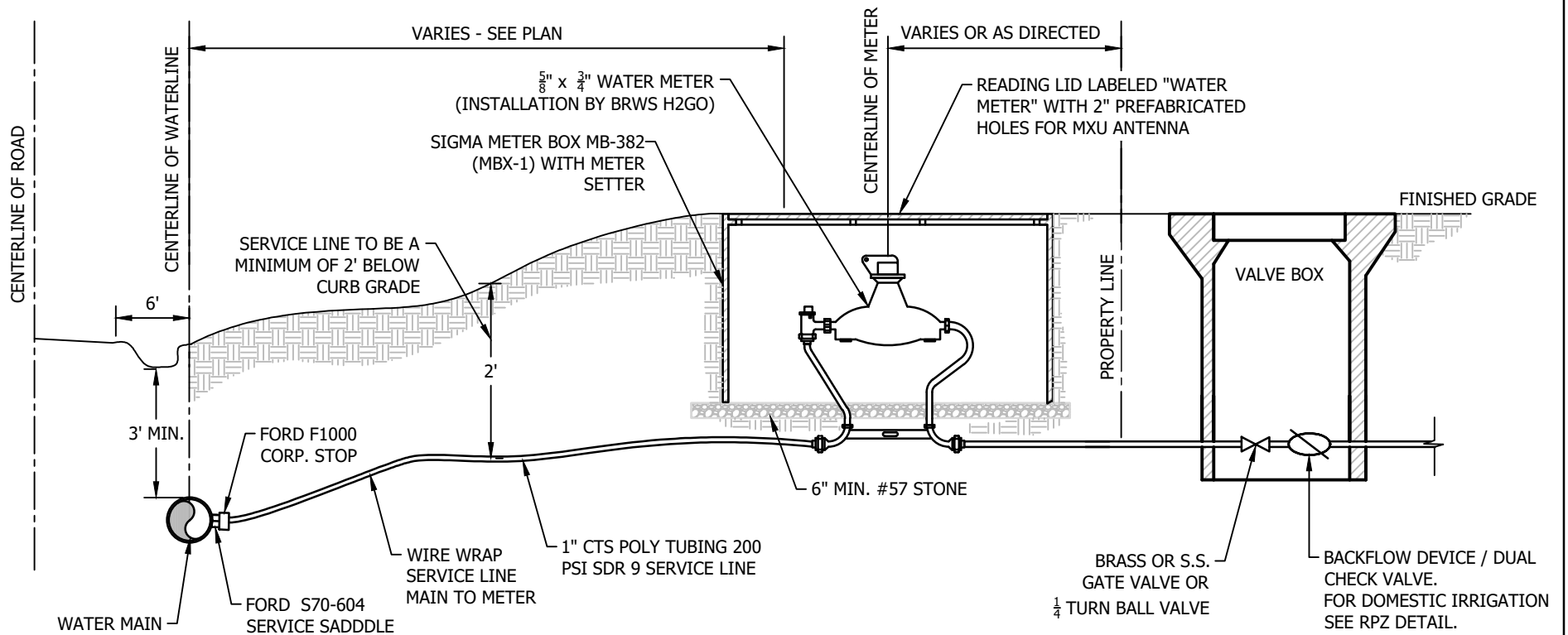

**NOTES:**

1. CONTRACTOR SHALL PLACE WATER METER BOX IN NON-TRAFFIC AREA AT LOCATION SPECIFIED BY BRWS H2GO.
2. ALL BRASS OR STAINLESS STEEL FITTINGS FROM METER SETTER TO / INCLUDING DUAL CHECK VALVE.
3. NO COUPLINGS BETWEEN MAIN LINE AND METER SETTER.



BRUNSWICK REGIONAL  
WATER AND SEWER H2GO

EFFECTIVE: APRIL 2022

**FORD YOKEBOX  
3/4" WATER SERVICE**

STD. NO.

2000.01

NOT TO SCALE

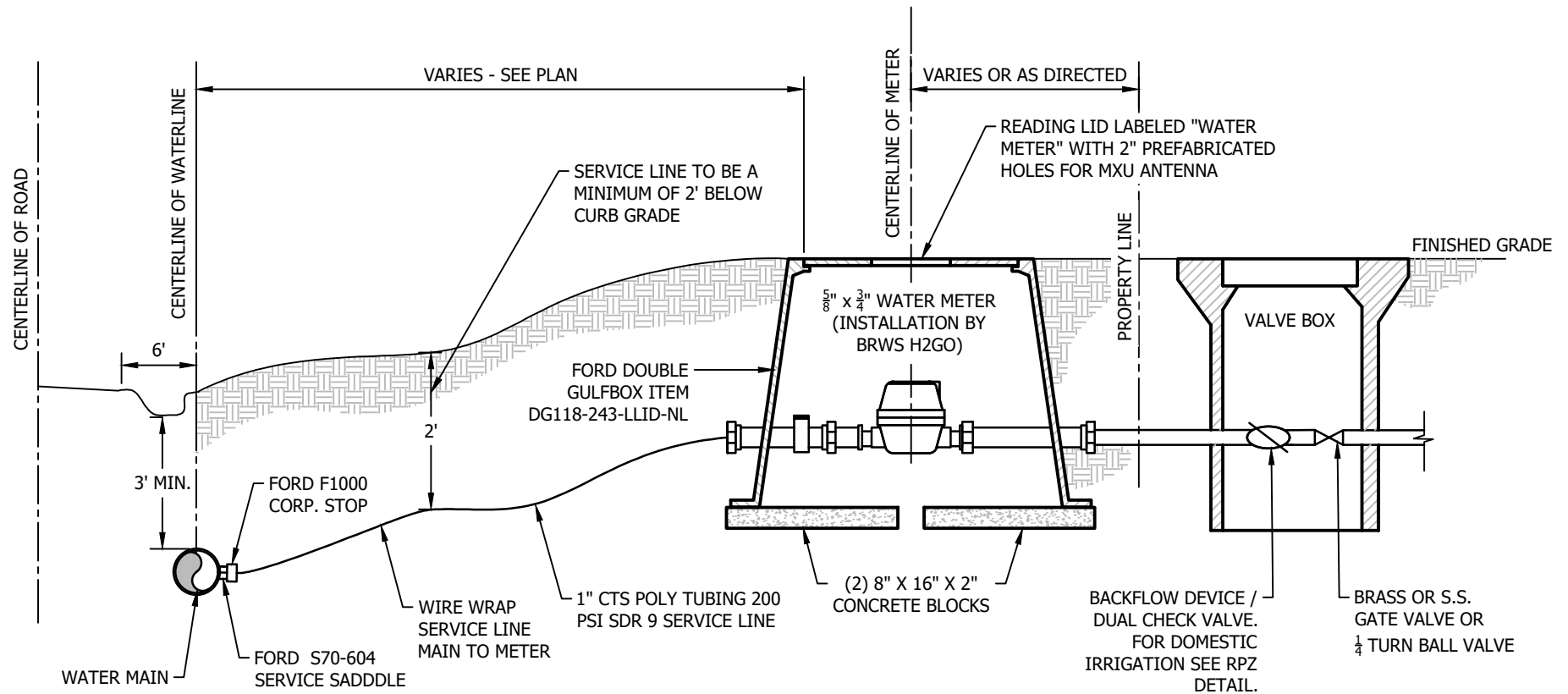

**NOTE:**

1. CONTRACTOR SHALL PLACE WATER METER BOX IN NON-TRAFFIC AREA AT LOCATION SPECIFIED BY BRWS H2GO.
2. ALL BRASS OR STAINLESS STEEL FITTINGS FROM METER SETTER TO / INCLUDING DUAL CHECK VALVE.
3. NO COUPLINGS BETWEEN MAIN LINE AND METER.



**BRUNSWICK REGIONAL  
WATER AND SEWER H2GO**

EFFECTIVE: NOVEMBER 2022

**FORD DOUBLE GULFBOX  
3/4" WATER SERVICE  
(DOMESTIC AND IRRIGATION)**

STD. NO.

**2000.02**

NOT TO SCALE

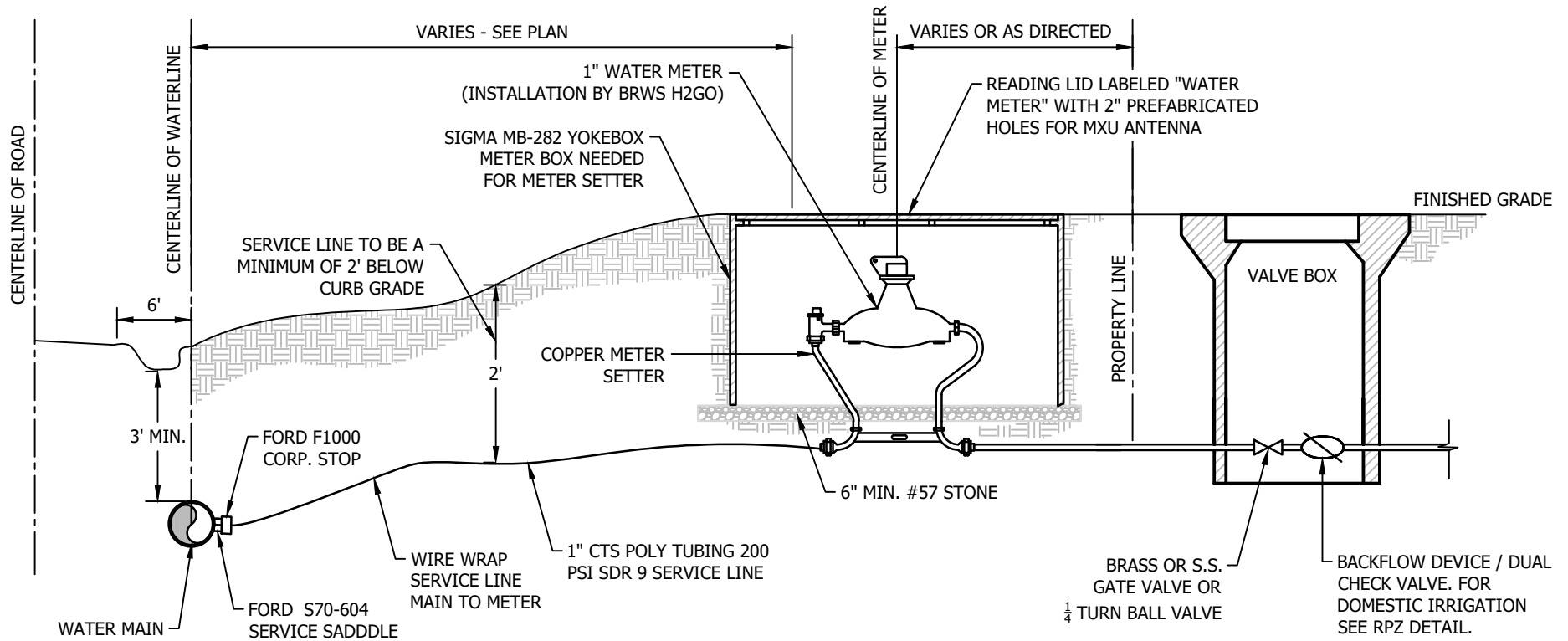

**NOTES:**

1. CONTRACTOR SHALL PLACE WATER METER BOX IN NON-TRAFFIC AREA AT LOCATION SPECIFIED BY BRWS H2GO.
2. ALL BRASS OR STAINLESS STEEL FITTINGS FROM METER SETTER TO / INCLUDING DUAL CHECK VALVE.



**BRUNSWICK REGIONAL  
WATER AND SEWER H2GO**

EFFECTIVE: APRIL 2022

# 1" WATER SERVICE

STD. NO.

**2000.03**

NOT TO SCALE



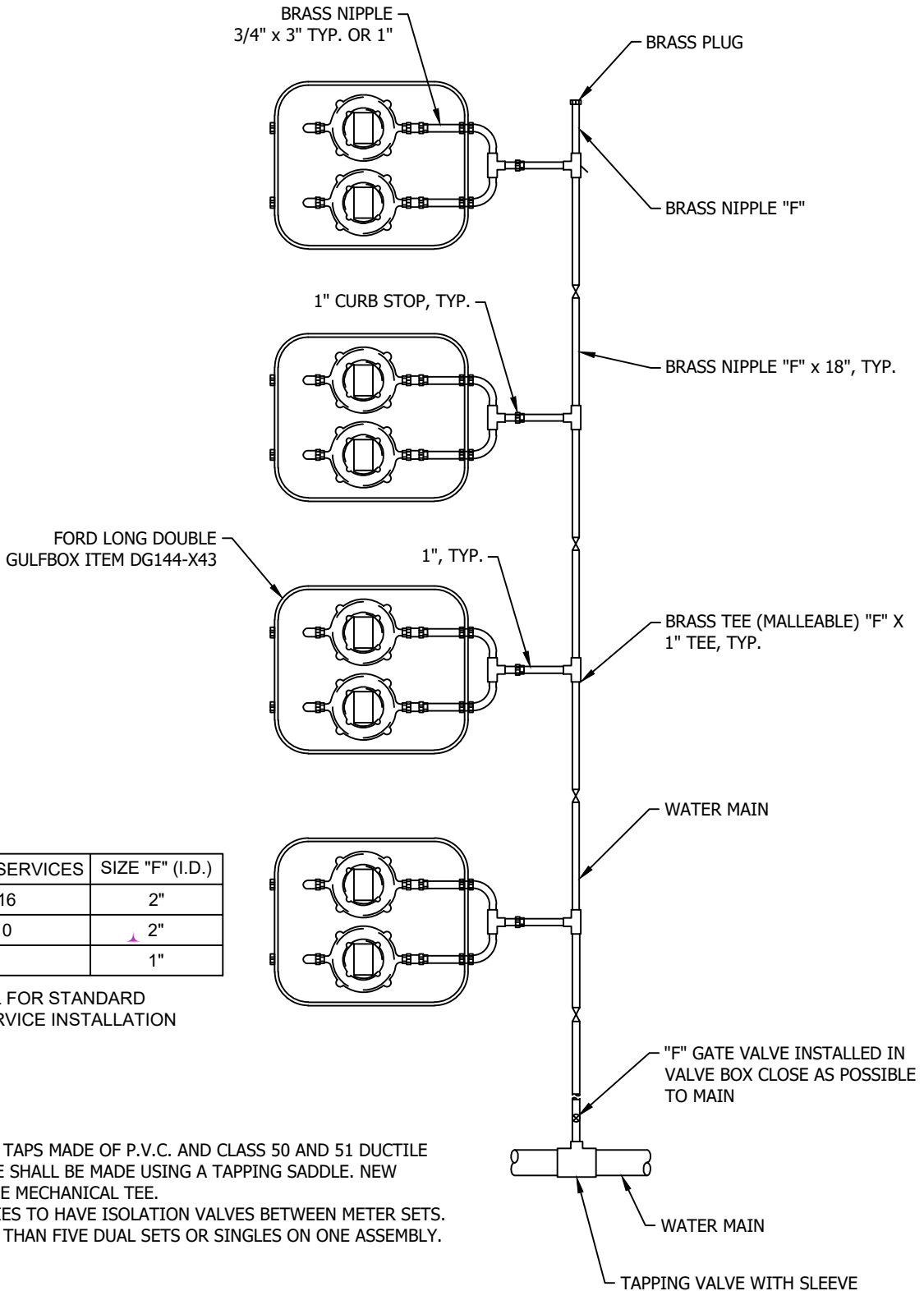

METERED SERVICES	SIZE "F" (I.D.)
11-16	2"
3-10	2"
2	1"

SEE DETAIL FOR STANDARD WATER SERVICE INSTALLATION

**NOTES:**

- EXISTING TAPS MADE OF P.V.C. AND CLASS 50 AND 51 DUCTILE IRON PIPE SHALL BE MADE USING A TAPPING SADDLE. NEW MAINS USE MECHANICAL TEE.
- ASSEMBLIES TO HAVE ISOLATION VALVES BETWEEN METER SETS.
- NO MORE THAN FIVE DUAL SETS OR SINGLES ON ONE ASSEMBLY.



BRUNSWICK REGIONAL  
WATER AND SEWER H2GO

EFFECTIVE: APRIL 2022

**STANDARD GANG  
METER ASSEMBLY**

STD. NO.

2000.05

NOT TO SCALE

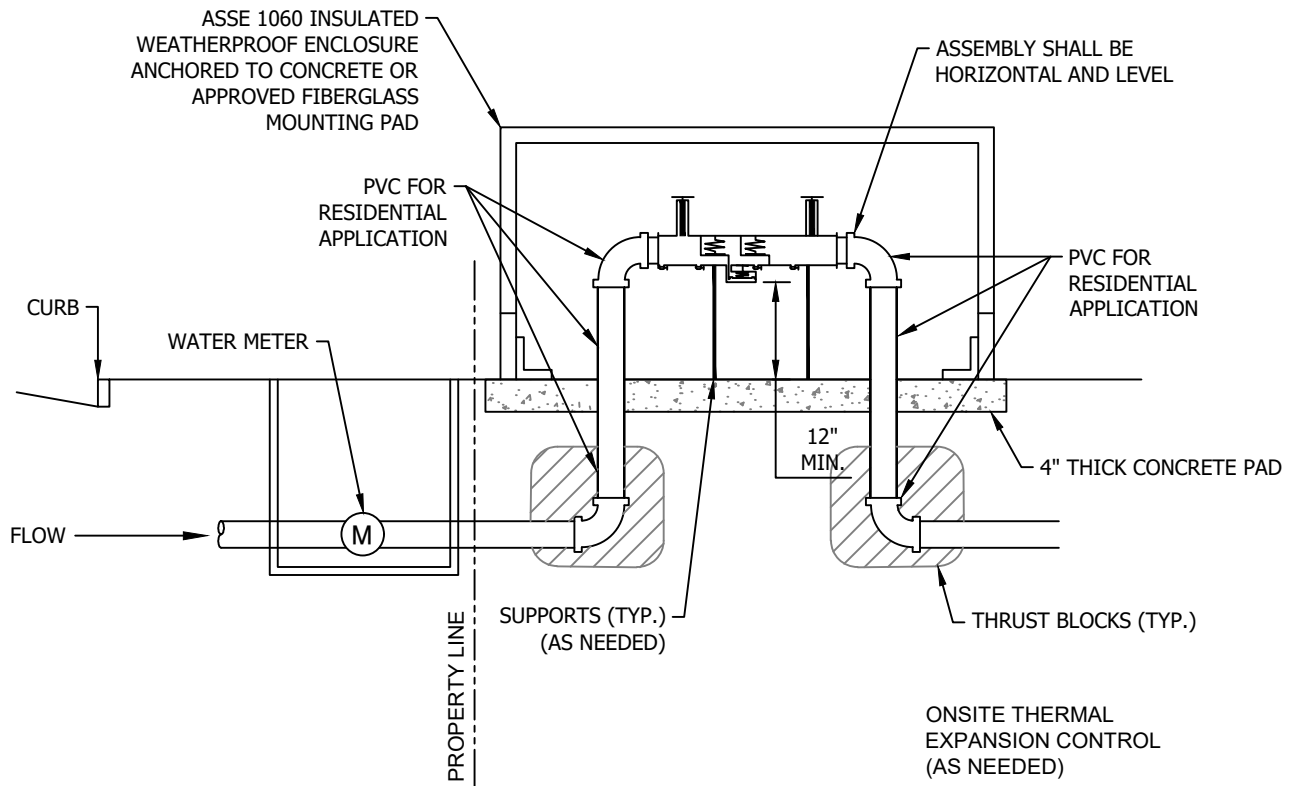

**NOTES:**

1. ALL BACKFLOW DEVICES TO COMPLY WITH USC STANDARDS.
2. ASSEMBLY SHALL BE LOCATED AS CLOSE TO THE SERVICE CONNECTION AS POSSIBLE WITH NO CONNECTIONS BETWEEN THE WATER METER AND THE BACKFLOW PREVENTION ASSEMBLY.
3. ALL PIPING SHOULD BE HYDRAULICALLY CALCULATED BY WATER USER FOR ONSITE USAGE
4. BACKFLOW PREVENTION ASSEMBLIES ARE TO BE USED WITHIN THEIR RATED OPERATING CONDITIONS.
  - 4.1. PRESSURE: BACKFLOW PREVENTION ASSEMBLIES TYPICALLY HAVE MAXIMUM WORKING WATER PRESSURES (MWWP) OF 150 PSI (1034 KPa) OR 175 PSI (1206 KPa). ASSEMBLIES ARE DESIGNED TO OPERATE CONTINUOUSLY AT THIS PRESSURE, WHICH IS IDENTIFIED ON THE ASSEMBLY.
  - 4.2. TEMPERATURE: BACKFLOW PREVENTION ASSEMBLIES ARE DESIGNED TO OPERATE CONTINUOUSLY AT THEIR MAXIMUM WORKING WATER TEMPERATURE (MWWT), WHICH IS IDENTIFIED ON THE ASSEMBLY.
  - 4.3. RATE OF FLOW: BACKFLOW PREVENTION ASSEMBLIES ARE DESIGNED TO OPERATE CONTINUOUSLY UP TO THEIR RATED FLOW (i.e. GALLONS PER MINUTE - GPM; OR LITERS PER SECOND - L/S).
5. NO VERTICAL ASSEMBLIES WILL BE ACCEPTED.



BRUNSWICK REGIONAL  
WATER AND SEWER H2GO

EFFECTIVE: APRIL 2022

RPZ DETAIL  
3/4" OR 1"

STD. NO.

2000.06

NOT TO SCALE

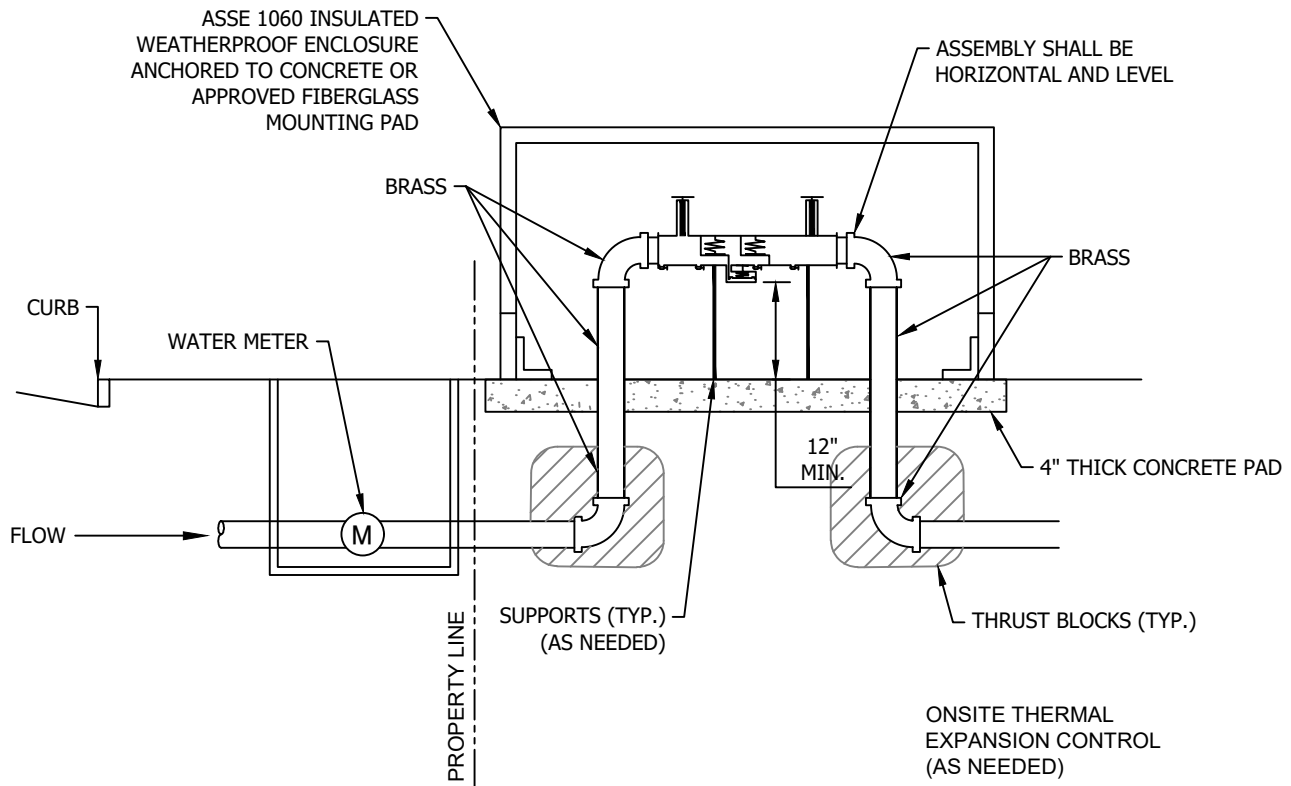

**NOTES:**

1. ALL BACKFLOW DEVICES TO COMPLY WITH USC STANDARDS.
2. ASSEMBLY SHALL BE LOCATED AS CLOSE TO THE SERVICE CONNECTION AS POSSIBLE WITH NO CONNECTIONS BETWEEN THE WATER METER AND THE BACKFLOW PREVENTION ASSEMBLY.
3. ALL PIPING SHOULD BE HYDRAULICALLY CALCULATED BY WATER USER FOR ONSITE USAGE.
4. BACKFLOW PREVENTION ASSEMBLIES ARE TO BE USED WITHIN THEIR RATED OPERATING CONDITIONS.
  - 4.1. PRESSURE: BACKFLOW PREVENTION ASSEMBLIES TYPICALLY HAVE MAXIMUM WORKING WATER PRESSURES (MWWP) OF 150 PSI (1034 KPa) OR 175 PSI (1206 KPa). ASSEMBLIES ARE DESIGNED TO OPERATE CONTINUOUSLY AT THIS PRESSURE, WHICH IS IDENTIFIED ON THE ASSEMBLY.
  - 4.2. TEMPERATURE: BACKFLOW PREVENTION ASSEMBLIES ARE DESIGNED TO OPERATE CONTINUOUSLY AT THEIR MAXIMUM WORKING WATER TEMPERATURE (MWWT), WHICH IS IDENTIFIED ON THE ASSEMBLY.
  - 4.3. RATE OF FLOW: BACKFLOW PREVENTION ASSEMBLIES ARE DESIGNED TO OPERATE CONTINUOUSLY UP TO THEIR RATED FLOW (i.e. GALLONS PER MINUTE - GPM; OR LITERS PER SECOND - L/S).
5. NO VERTICAL ASSEMBLIES WILL BE ACCEPTED.



BRUNSWICK REGIONAL  
WATER AND SEWER H2GO

EFFECTIVE: APRIL 2022

RPZ DETAIL  
2" + UP

STD. NO.

2000.07

NOT TO SCALE



NOTES:

1. HYDRANT TO BE PLACED WITH PUMPER NOZZLE FACING THE TRAVEL/FIRE LANE.
2. IF HYDRANT IS LOCATED ON A DEPARTMENT OF TRANSPORTATION ROADWAY USE D.O.T. STANDARDS FOR LOCATION OF HYDRANT.
3. PROVIDE BARREL EXTENSION SECTION AS REQUIRED FOR PROPER VERTICAL ALIGNMENT.
4. ALL HYDRANTS ARE TO BE RED IN COLOR.

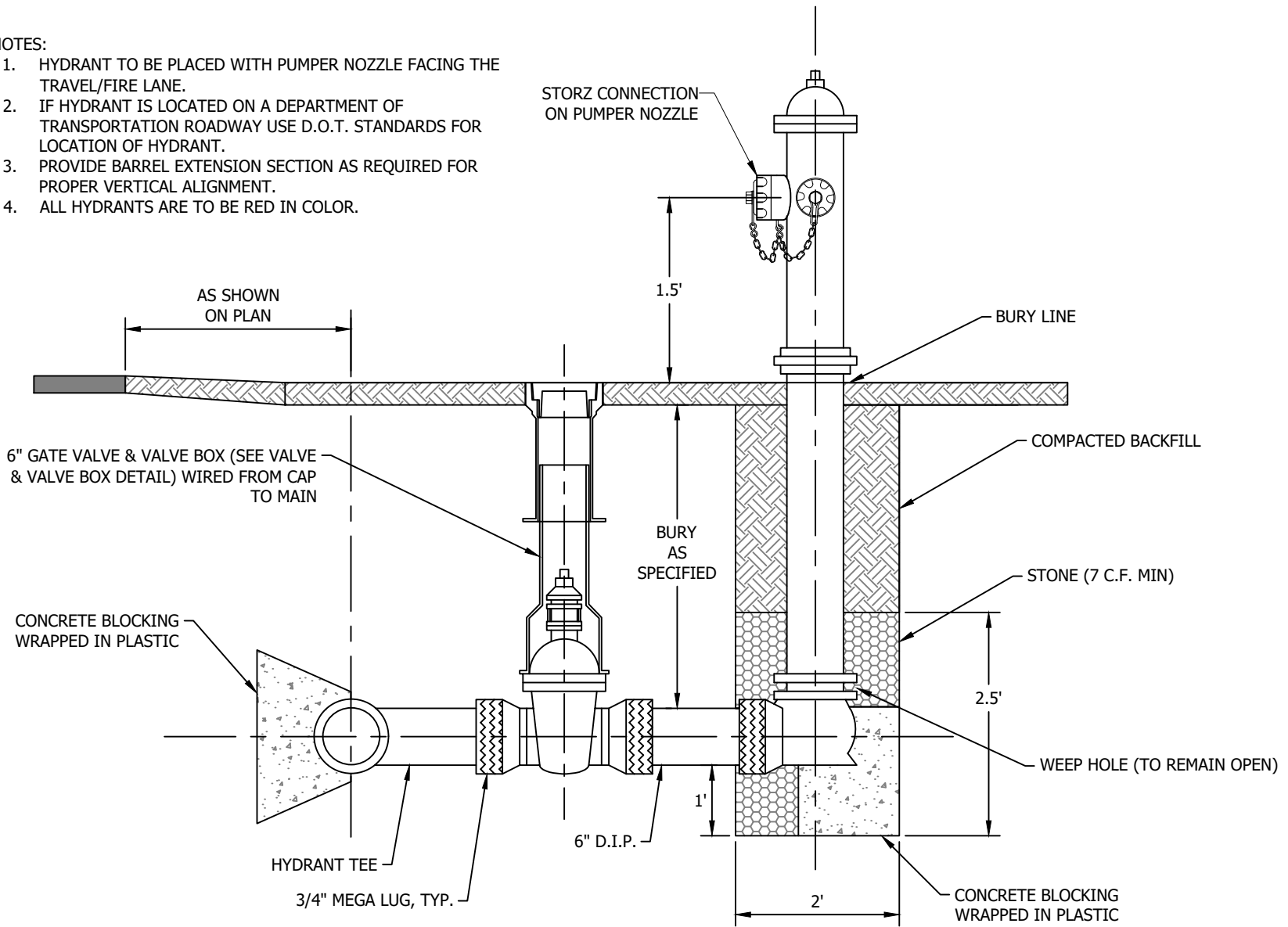

BRUNSWICK REGIONAL  
WATER AND SEWER H2GO

EFFECTIVE: APRIL 2022

# FIRE HYDRANT ASSEMBLY

STD. NO.

2000.08

NOT TO SCALE

NOTES:

1. HYDRANT TO BE PLACED WITH PUMPER NOZZLE FACING THE TRAVEL/FIRE LANE.
2. IF HYDRANT IS LOCATED ON A DEPARTMENT OF TRANSPORTATION ROADWAY USE D.O.T. STANDARDS FOR LOCATION OF HYDRANT.
3. PROVIDE BARREL EXTENSION SECTION AS REQUIRED FOR PROPER VERTICAL ALIGNMENT.
4. ALL HYDRANTS ARE TO BE RED IN COLOR.

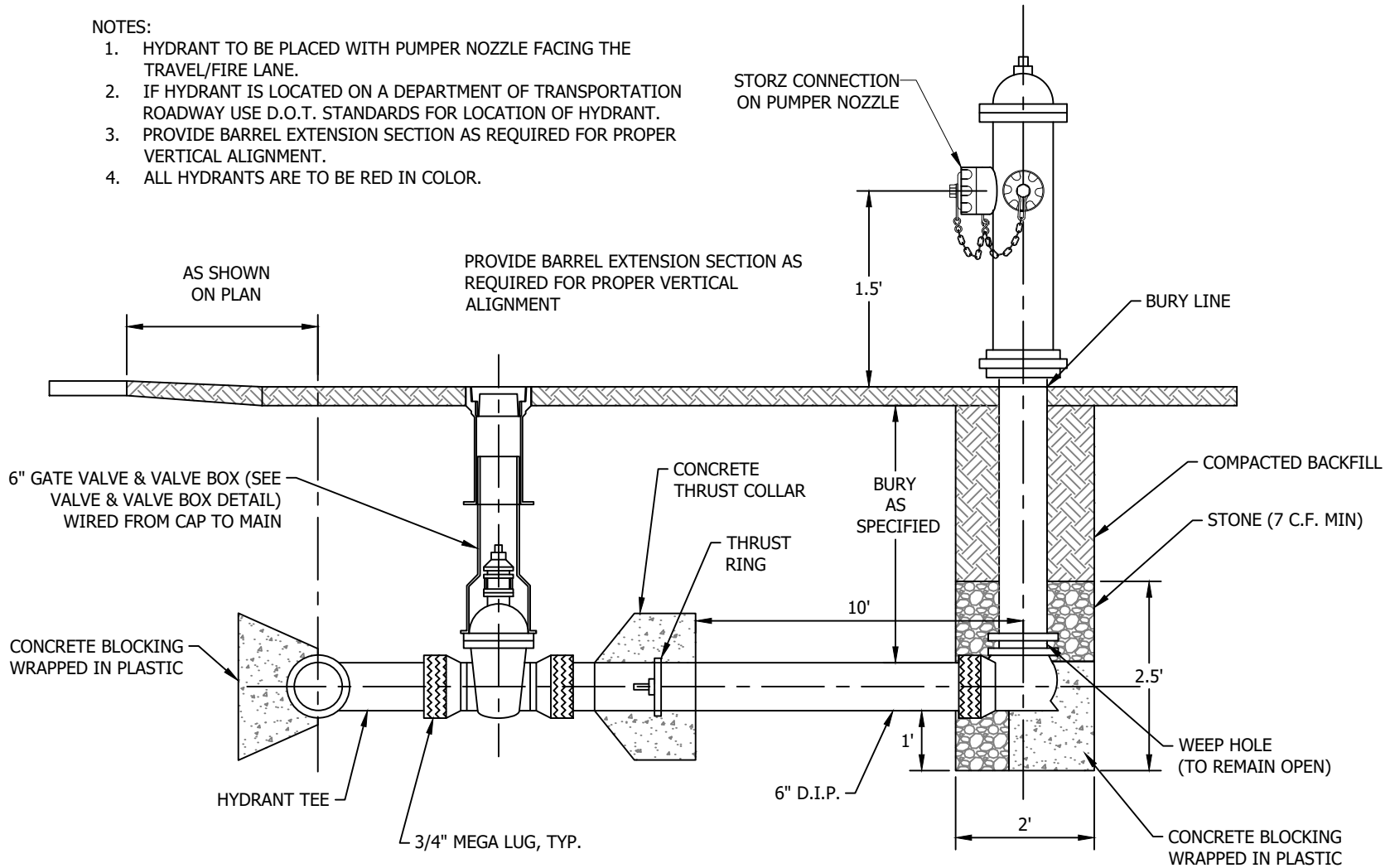

BRUNSWICK REGIONAL  
WATER AND SEWER H2GO

EFFECTIVE: APRIL 2022

## FIRE HYDRANT ASSEMBLY (FAR SIDE)

STD. NO.

2000.09

NOT TO SCALE

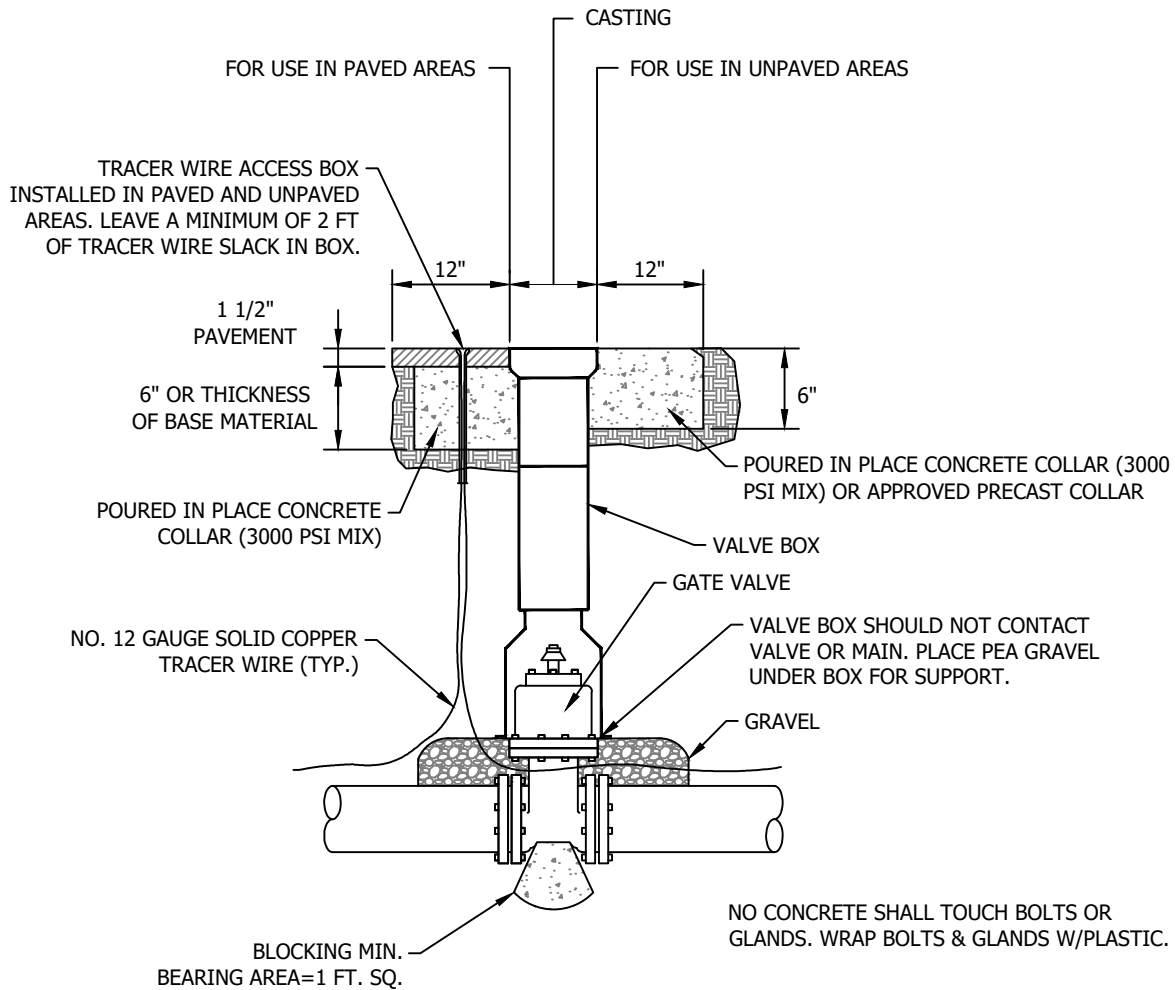

**NOTES:**

1. 2" GATE VALVES SHALL F.I.P. THREADS. CONNECTION TO THE PIPE SHALL BE MADE WITH BRASS NIPPLE AND SCH. 40 PVC F.I.P.T. X SLIP ADAPTERS.
2. GATE VALVES GREATER THAN 2" SHALL BE MECHANICAL JOINT.
3. TRACER WIRE ACCESS BOX SHALL BE VALVCO TYPE OR APPROVED EQUAL.
4. FASTEN TRACER WIRE TO PIPE WITH ZIP TIES AROUND THE CIRCUMFERENCE OF PIPE AT 10' INTERVALS (TYP.).



BRUNSWICK REGIONAL  
WATER AND SEWER H2GO

EFFECTIVE: APRIL 2022

M.J. VALVE AND  
VALVE BOX

STD. NO.

2000.10

NOT TO SCALE

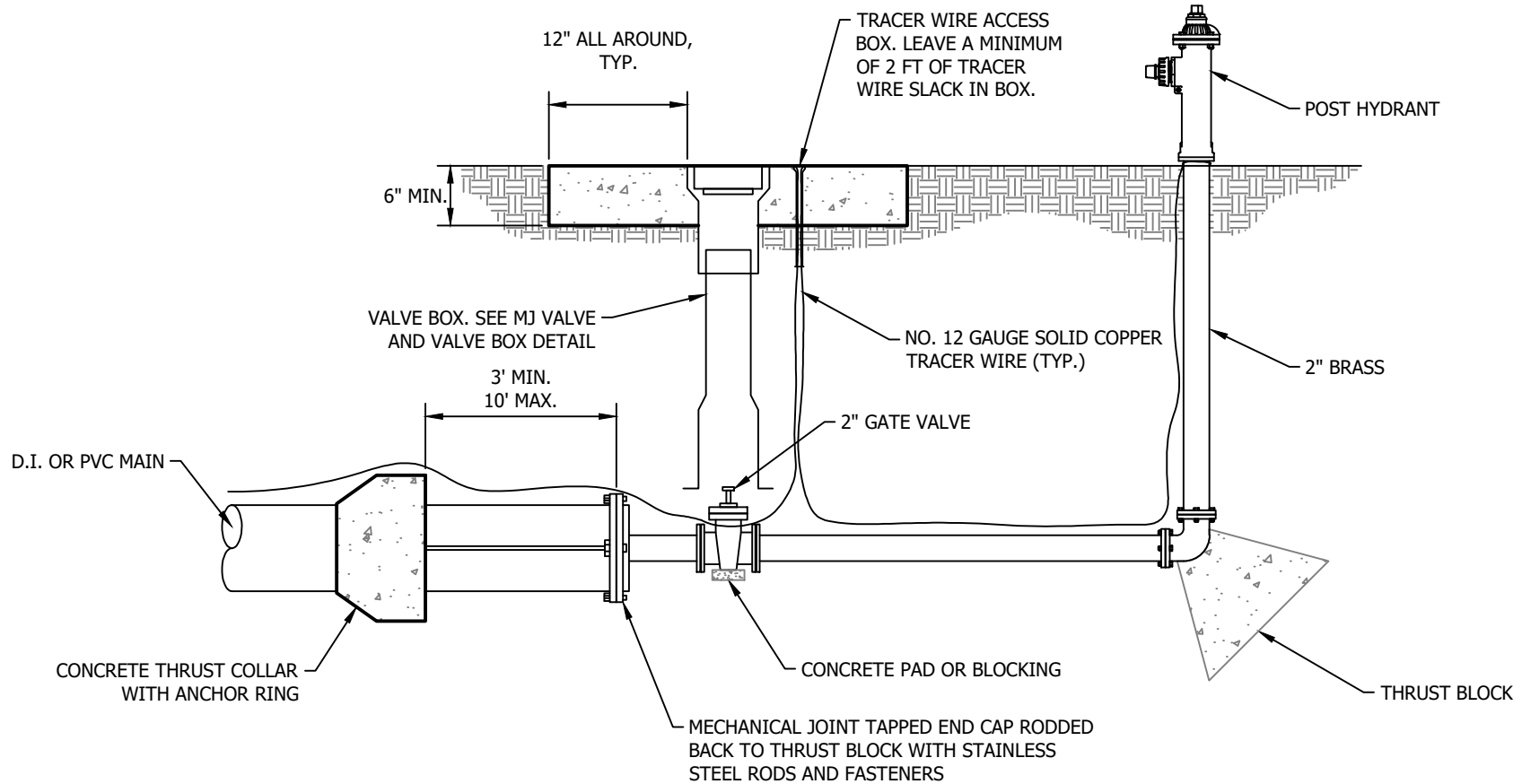

**NOTES:**

1. SEE SPECIFICATIONS FOR SUPPORT OF VALVE & VALVE BOX IN SOILS OTHER THAN LOOSE DRY SAND.
2. ASSEMBLIES TO BE #2 ECLIPSE POST HYDRANT.
3. HYDRANT SHALL NOT BE INSTALLED IN SIDEWALKS, CONCRETE, OR PAVED AREAS.
4. TRACER WIRE ACCESS BOX SHALL BE VALVCO TYPE OR APPROVED EQUAL.



BRUNSWICK REGIONAL  
WATER AND SEWER H2GO

EFFECTIVE: APRIL 2022

# 2" HYDRANT BLOWOFF ASSEMBLY

STD. NO.

2000.11

NOT TO SCALE

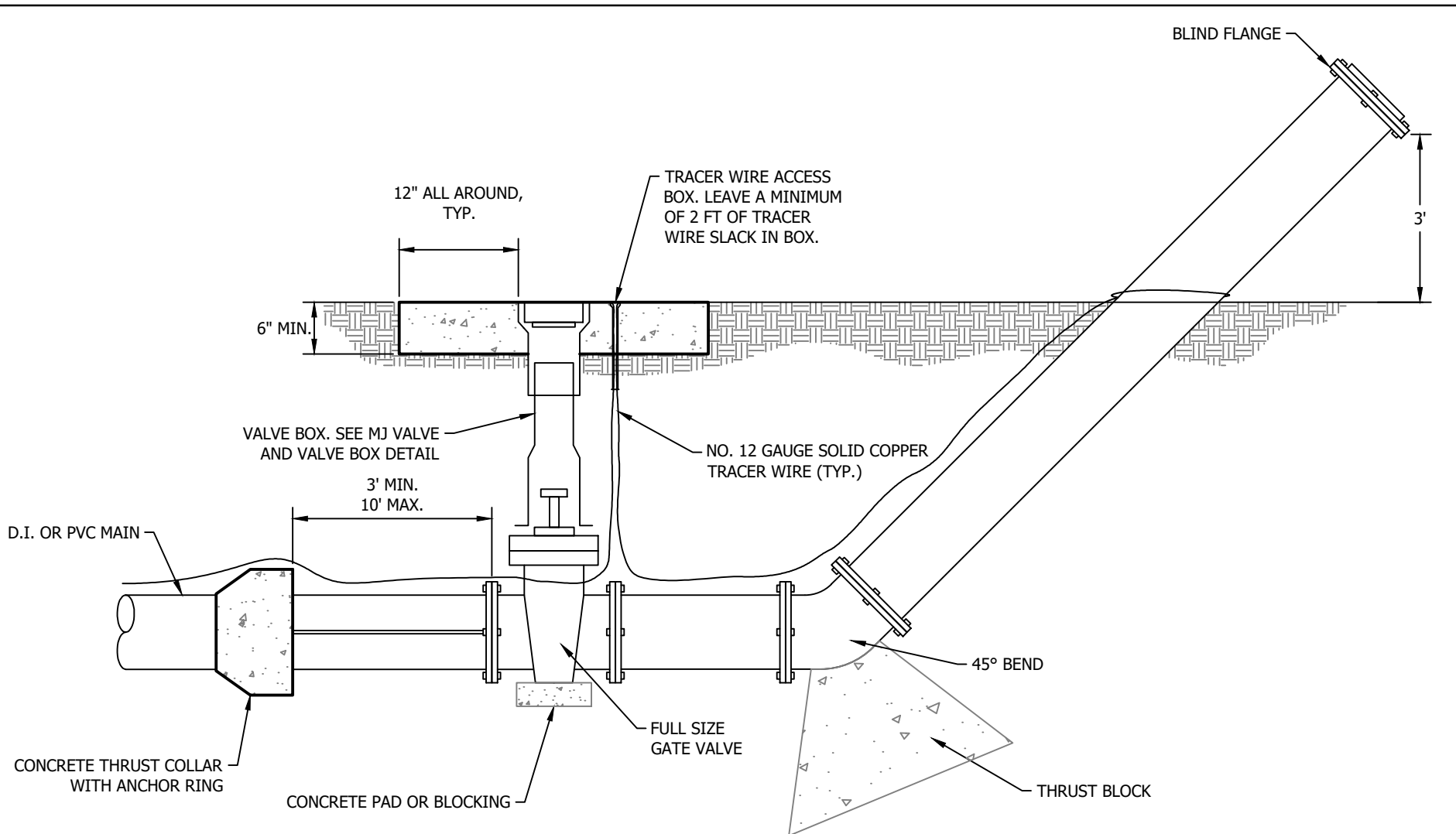

**NOTES:**

1. SEE SPECIFICATIONS FOR SUPPORT OF VALVE & VALVE BOX IN SOILS OTHER THAN LOOSE DRY SAND.
2. BLOW OFF SHALL BE FULL PIPE SIZE BROUGHT UP WITH A 45° BEND WITH APPROPRIATE RESTRAINT.
3. BLOW OFF SHALL NOT BE INSTALLED IN SIDEWALKS, CONCRETE, OR PAVED AREAS.
4. TRACER WIRE ACCESS BOX SHALL BE VALVCO TYPE OR APPROVED EQUAL.



**BRUNSWICK REGIONAL  
WATER AND SEWER H2GO**  
EFFECTIVE: APRIL 2022

**TEMPORARY BLOWOFF**

STD. NO.
2000.12
NOT TO SCALE

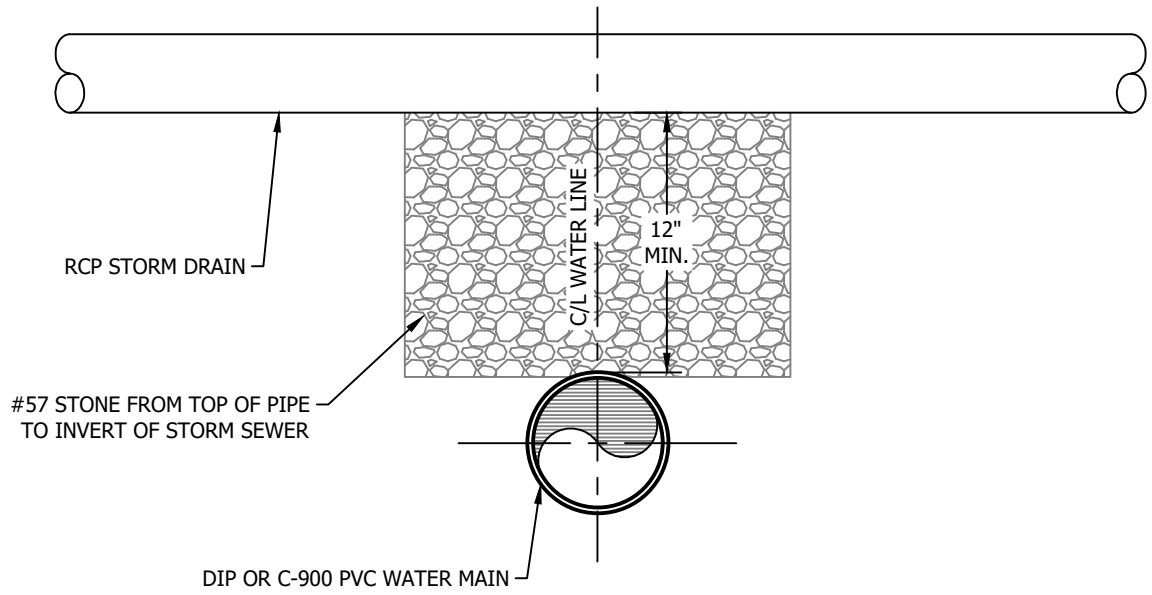

BRUNSWICK REGIONAL  
 WATER AND SEWER H2GO  
 EFFECTIVE: APRIL 2022

# WATER & STORM DRAIN INTERSECTION

STD. NO.  
 2000.13  
 NOT TO SCALE

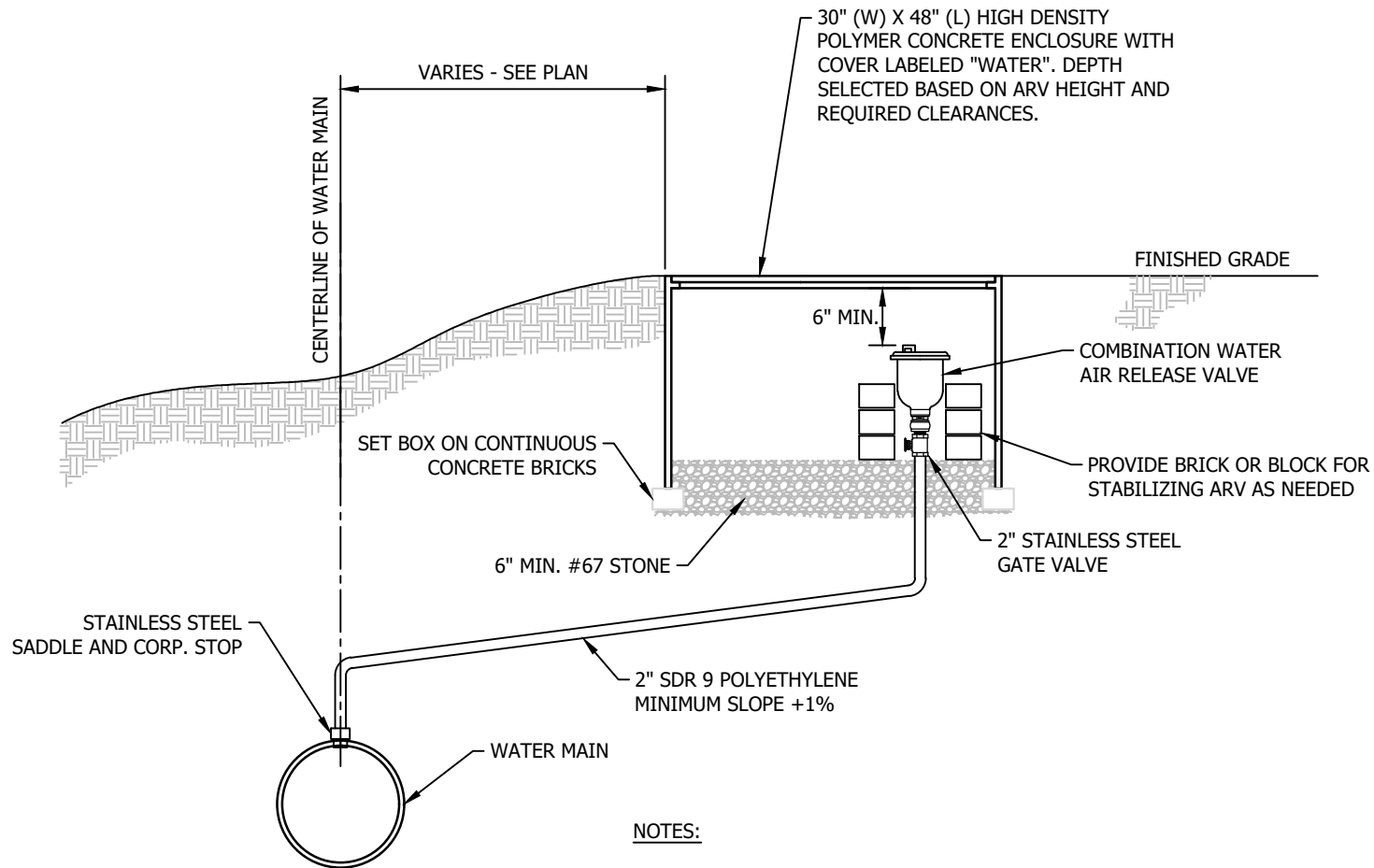

**NOTES:**

1. ROTATION AND LOCATION OF BOX TO BE APPROVED BY BRWS H2GO.
2. ARV ASSEMBLIES INSTALLED IN ROAD RIGHT-OF-WAY MUST BE FLUSH WITH EXISTING SHOULDER GRADE.
3. ARV ASSEMBLY SHOULD BE OFFSET TO ONE SIDE OF BOX AS SHOWN TO ALLOW EASIER ACCESS FOR OPERATION AND MAINTENANCE.
4. 2" STAINLESS STEEL NIPPLES AND COUPLINGS SHALL BE USED IF NEEDED.



BRUNSWICK REGIONAL  
WATER AND SEWER H2GO

EFFECTIVE: APRIL 2022

# OFFSET COMBINATION POTABLE WATER AIR RELEASE VALVE

STD. NO.

2000.14

NOT TO SCALE

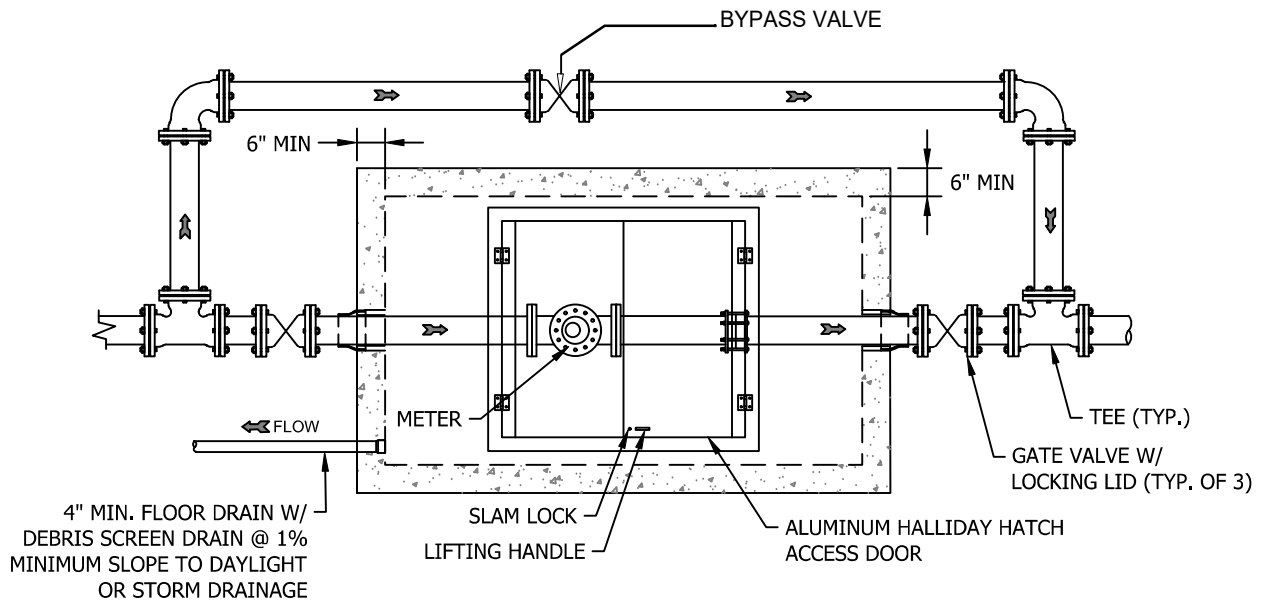

**PLAN VIEW**

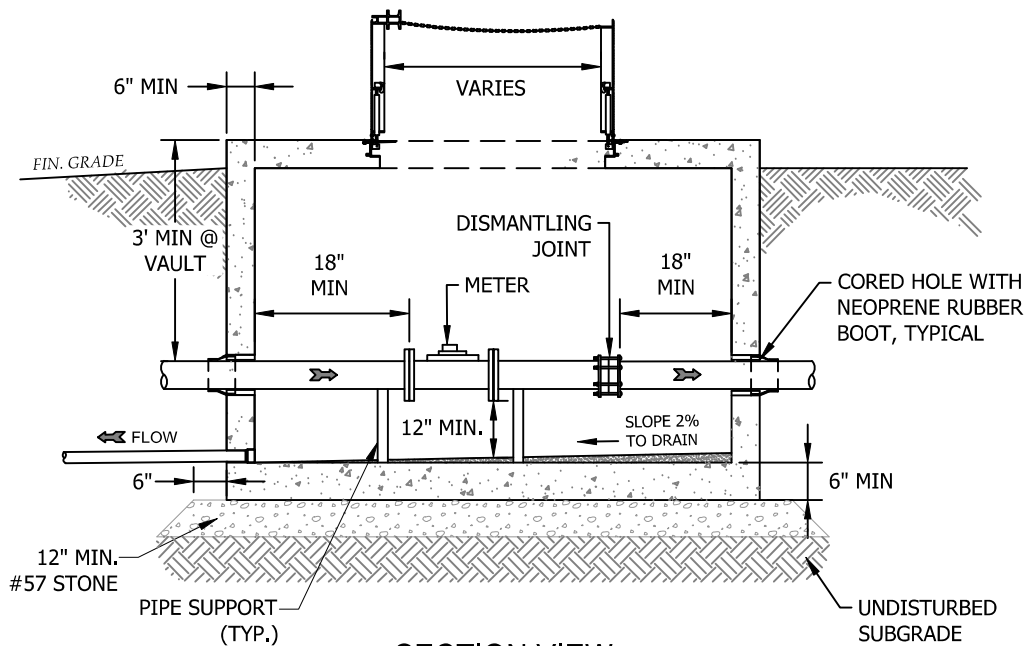

**SECTION VIEW**

**NOTES:**

1. ALL PIPING SHOWN TO BE DUCTILE IRON.
2. ALL METER VAULTS AND ACCESS DOORS WITHIN THE ROAD RIGHTS-OF-WAY SHALL MEET HS-20 LOADING REQUIREMENTS.
3. TO ENSURE POSITIVE DRAINAGE, THE VAULT SHALL BE TIED INTO THE EXISTING STORM DRAINAGE SYSTEM, IF POSITIVE DRAINAGE IS UNOBTAINABLE, A SUMP PUMP SHALL BE LOCATED AND OPERATED IN THE VAULT.
4. SEPARATE STRAINER SHALL BE REQUIRED IF PROPOSED METER DOES NOT HAVE AN INTEGRAL STRAINER.
5. ACCESS HATCH SHALL BE SIZED TO ACCOMMODATE METER WITH A MINIMUM CLEARANCE OF 6" ON ALL SIDES.



**BRUNSWICK REGIONAL  
WATER AND SEWER H2GO**

EFFECTIVE: OCTOBER 2022

**WATER METER VAULT WITH  
BYPASS (3" AND GREATER)**

STD. NO.

**2000.15**

NOT TO SCALE



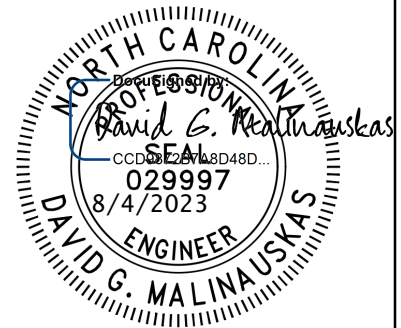
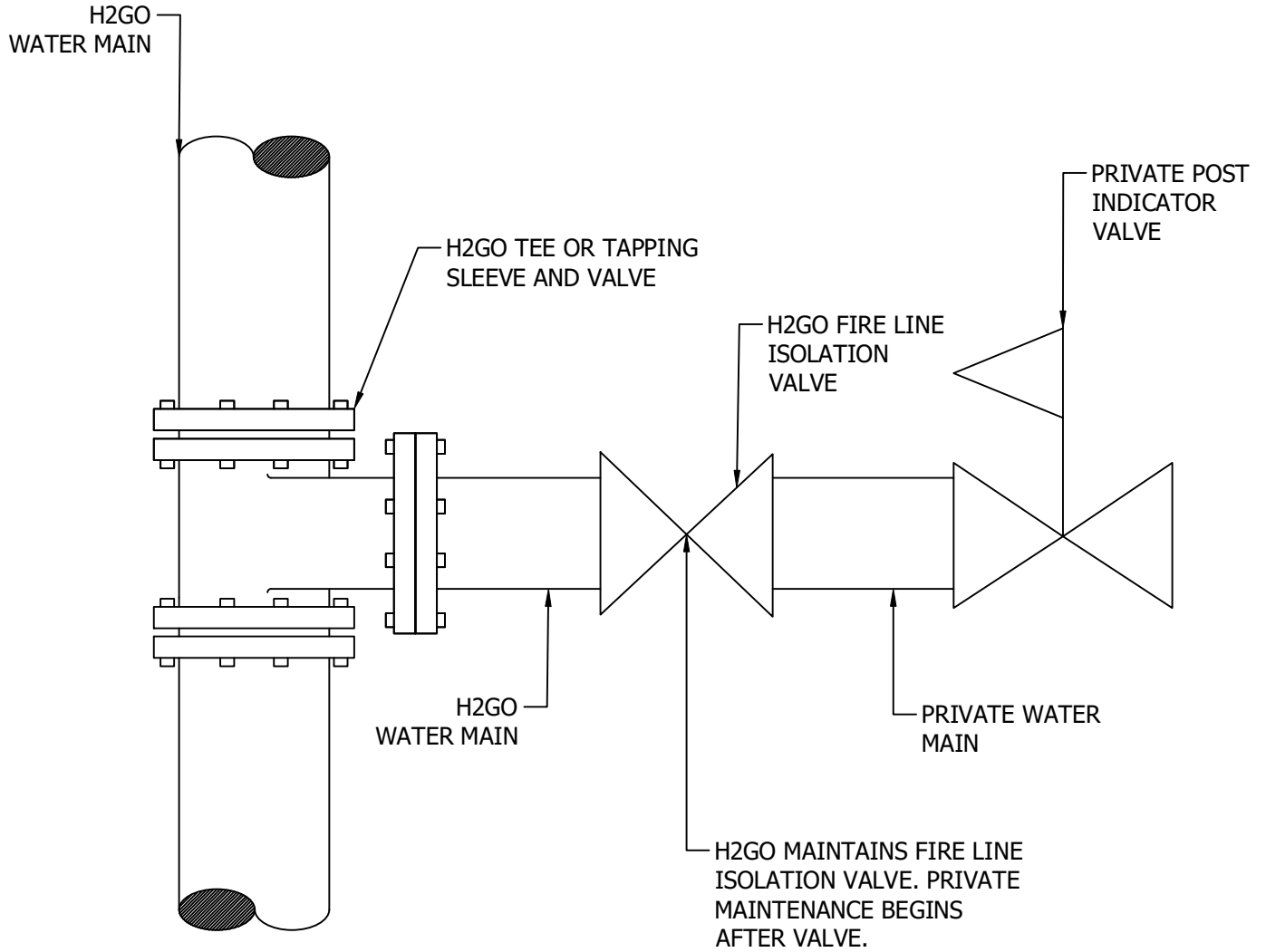

BRUNSWICK REGIONAL  
WATER AND SEWER H2GO  
EFFECTIVE: AUGUST 2023

# FIRE LINE ISOLATION VALVE

STD. NO.  
2000.16  
NOT TO SCALE

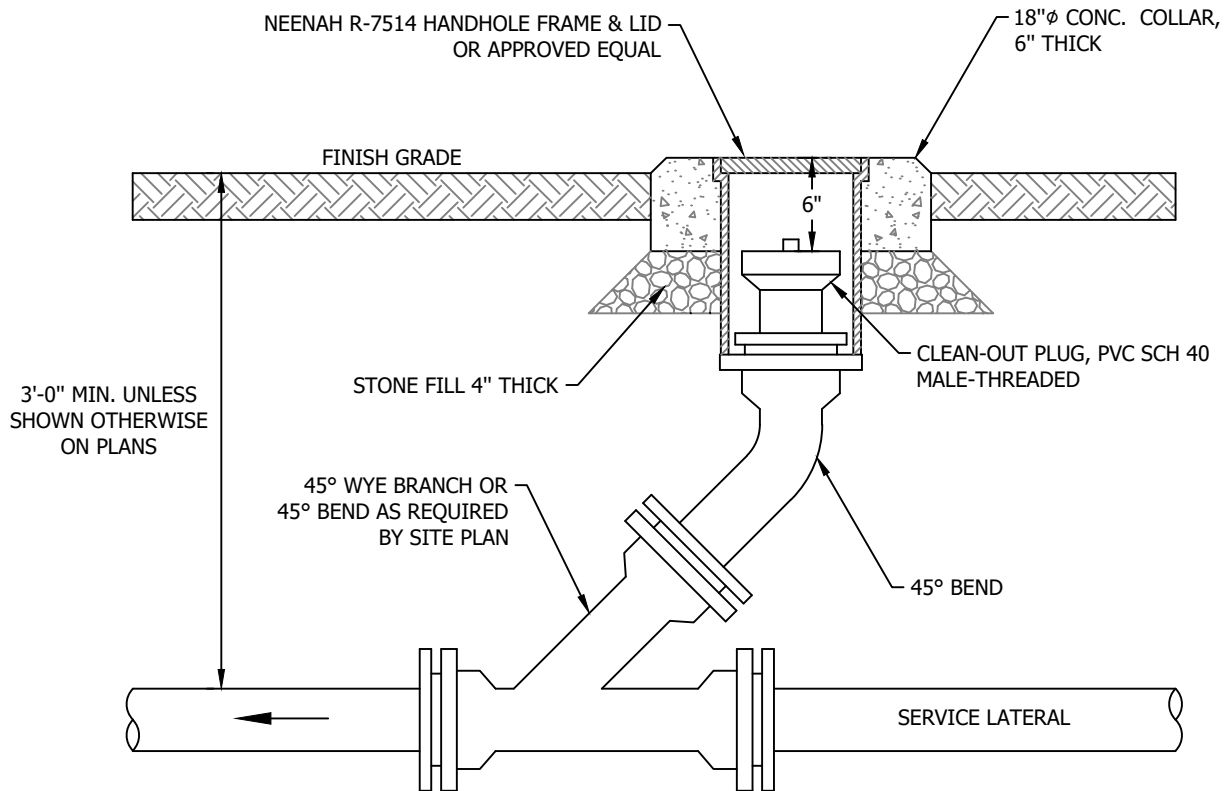

**NOTES:**

1. CLEAN-OUT PIPE AND FITTINGS SHALL BE THE SAME DIAMETER AND MATERIAL AS THE SERVICE LATERAL.
2. PROVIDE CLEAN-OUTS WHERE INDICATED ON THE PLANS.
3. D.I.P. CLEAN-OUTS SHALL HAVE BRONZE-THREADED CLEAN-OUT PLUG.
4. WHERE CLEAN-OUTS ARE INSTALLED ON PIPING UNDER PRESSURE, ALL JOINTS SHALL HAVE RETAINER GLANDS OR OTHER APPROVED METHOD OF RESTRAINT. ALL RISER PIPE, FITTINGS AND CLEAN-OUT PLUG SHALL BE WATERTIGHT AND RATED FOR THE PRESSURES PRESENT AT THE PARTICULAR POINT OF INSTALLATION.



BRUNSWICK REGIONAL  
WATER AND SEWER H2GO

EFFECTIVE: APRIL 2022

SANITARY SEWER SERVICE  
LATERAL CLEANOUT

STD. NO.

3000.01

NOT TO SCALE

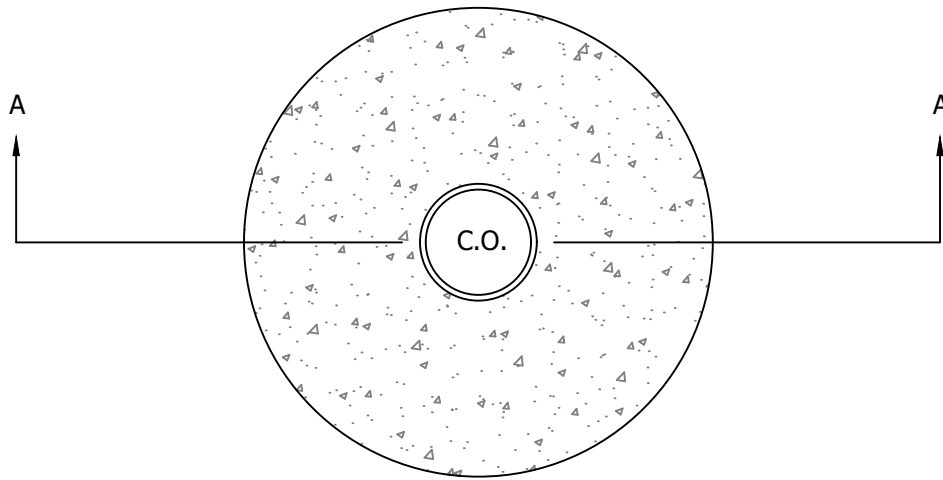

PLAN

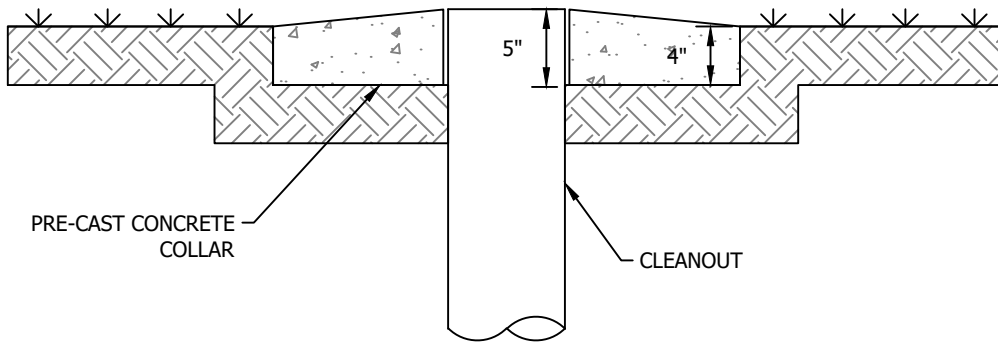

SECTION A-A



BRUNSWICK REGIONAL  
WATER AND SEWER H2GO

EFFECTIVE: APRIL 2022

# CLEANOUT PAD

STD. NO.

3000.02

NOT TO SCALE

**PRESSURE SEWER SERVICE NOTES:**

WET TAPPING; SERVICE SADDLES FOR WET TAPPING OF PRESSURE SEWER LINES SHALL BE FORD SERIES FS202, OR APPROVED EQUAL SADDLE WITH STAINLESS STEEL BAND. OUTLET THREADS SHALL BE IRON PIPE SIZE. VALVING MECHANISM SHALL BE FORD CORPORATION STOP SERIES FB500, OR APPROVED EQUAL CORPORATION STOP WITH INLET AND OUTLET BEING MALE IRON PIPE THREADS. CONNECTION BETWEEN THE CORPORATION STOP AND SCH. 40 SERVICE LINE SHALL BE ACCOMPLISHED USING A SCH. 40 PVC IRON PIPE THREAD BY SLIP COUPLING. WHERE CONNECTION IS TO BE MADE TO 2" PRESSURE SEWER LINE, SAID CONNECTION MAY BE MADE BY CUTTING INTO THE LINE AND INSERTING A 2" SCH. 40 TEE IF SAID CONNECTION CAN BE MADE WHILE TAKING THE LINE OUT OF SERVICE FOR NO MORE THAN 15 MINUTES.

**PROXIMITY TO WATER SUPPLY LINES:**

WHERE SEWER SERVICES CROSS WATER SUPPLY LINES, THE SEWER SHALL BE INSTALLED A MINIMUM OF 18" BELOW THE WATER LINE. (CONVERSELY, WHERE WATER SERVICE LINES CROSS SEWER MAINS, THE WATER LINE SHALL BE INSTALLED A MINIMUM OF 18" ABOVE THE SEWER MAIN AS NOTED ON THE "WATER DISTRIBUTION SYSTEM DETAIL SHEET.")

**SPECIAL NOTE:**

THE SERVICE FOR ANY PLATTED LOT SHALL BE INSTALLED AT THE TIME PRESSURE SEWER MAIN SERVING THE LOT IS CONSTRUCTED. WET TAPPING FOR SERVICES SHALL BE ALLOWED ONLY FOR AREAS WHERE LOTS WERE NOT PLATTED AT THE TIME ADJACENT SEWER MAINS WERE CONSTRUCTED. WHEN ANY SERVICE TAP IS MADE, THE VALVE BOX, GATE VALVE, AND METER BOX SHALL BE INSTALLED, AND THE SERVICE LINE SHALL BE CONTINUED AT LEAST TO THE RIGHT-OF-WAY LINE.

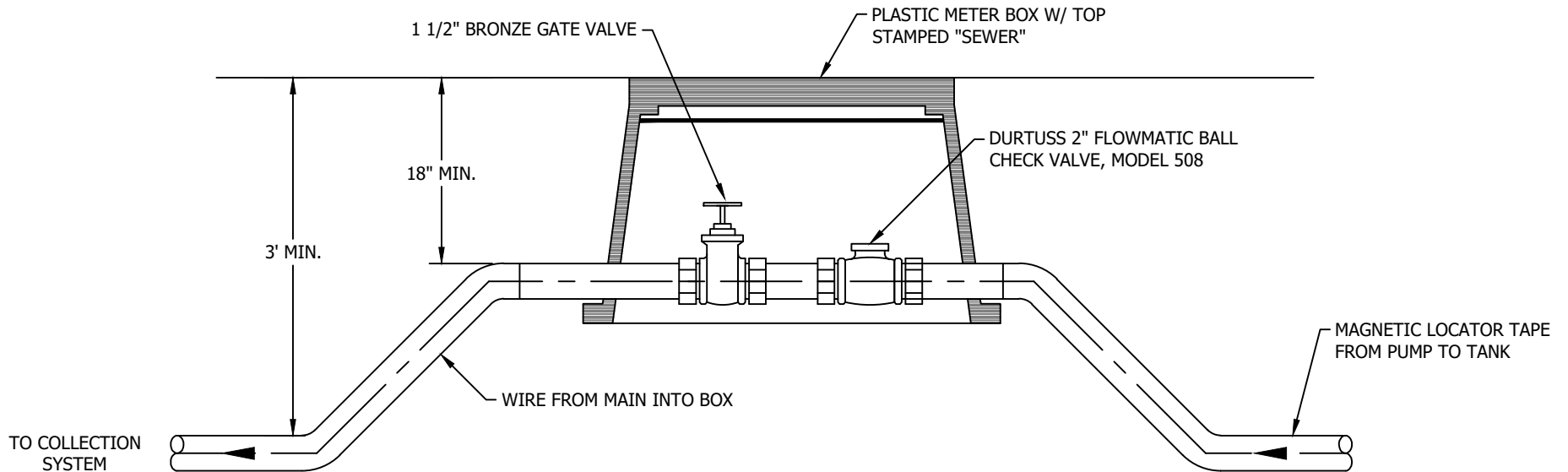

**NOTE:**

PIPE AND FITTINGS TO BE 1 1/2" SCH. 40 PVC UNLESS OTHERWISE NOTED. SCH. 80 PVC ADAPTERS SHALL BE PROVIDED AT EACH END OF VALVES.



BRUNSWICK REGIONAL  
WATER AND SEWER H2GO

EFFECTIVE: APRIL 2022

# SERVICE LINE VALVE BOX

STD. NO.

3000.03

NOT TO SCALE

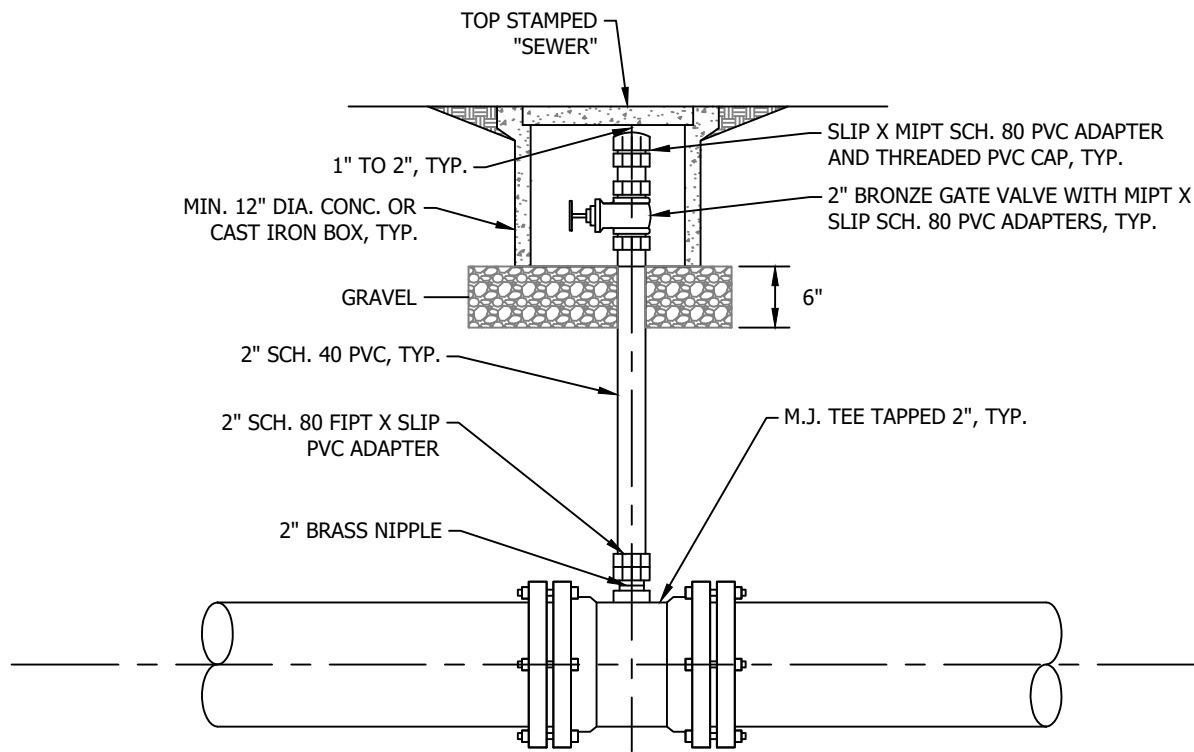

**NOTES:**

1. SLOPE FINISH GRADE TO DRAIN AWAY FROM BOX.
2. WHERE PRESSURE SEWER IS 3" OR LARGER TEE SHALL BE M.J. WITH 2" TAP. 2" SCH. 80 PVC TEE MAY BE USED FOR 2" PRESSURE SEWER.
3. IN LINE CLEANOUT SHALL BE LOCATED APPROXIMATELY 2' FROM ADJACENT GATE VALVE.



BRUNSWICK REGIONAL  
WATER AND SEWER H2GO

EFFECTIVE: APRIL 2022

# IN-LINE PRESSURE SEWER CLEANOUT

STD. NO.

3000.04

NOT TO SCALE

FRAME & COVER (SEE DETAIL), BOLTED AND MORTARED, ROUNDED AS SHOWN

BITUMINOUS IMPREGNATED YARN FRAME SEAL

6" MAX. FOR SPACER

TYPE "N" MASONRY MORTAR, 1" MAXIMUM

4' MAX.

PRECAST 48" MANHOLE SECTIONS AS REQUIRED, ASTM C478 INTEGRAL FLOOR, UNLESS SHOWN OTHERWISE. MINIMUM NUMBER OF JOINTS.

4"  
6" MIN.

CONCRETE BASE

24" MANHOLE RING & COVER WITH DRIP PAN AND RAIN GUARDS INSIDE MANHOLE.

USE 3/8" ANCHOR BOLTS TO BOLT FRAME TO SPACER. USE ROPE MASTIC SEAL BETWEEN FRAME & SPACER

PRECAST CONCRETE GRADE ADJUSTMENT RINGS-MIN. 4" HIGH (MAXIMUM OF 2)

ECCENTRIC TAPER UNIT

RISER UNIT

16" TYP.

RISER UNIT

BASE UNIT

8"

6"

4' DIA. (MIN.)

16" MAX.

CONCRETE

BUTYL RUBBER BASED FLEXIBLE JOINT SEALANT OR O-RING GASKET WITH A 4" WIDE BUTYL RUBBER WRAP OUTSIDE

SEE NOTE 3

SEE NOTE 2

PIPE TO BE CONNECTED TO MANHOLE WITH FLEXIBLE SLEEVE WITH TWO STAINLESS STEEL PIPE CLAMPS

CONCRETE

AGGREGATE BED, NO. 57 STONE

**NOTES:**

1. NEOPRENE BOOT, KOR-N-SEAL OR EQUAL, TO BE USED ON ALL PRECAST MANHOLES WITH ALL TYPES OF PIPES.
2. TWO STAINLESS STEEL PIPE CLAMPS (300-SERIES NON-MAGNETIC CORROSION-RESISTANT STEEL).
3. EXPANSION BAND (KORBAND 6061-T6 ALUMINUM ALLOY WITH A BLACK ANODIZED SURFACE
4. USE STAINLESS STEEL DRIP PANS ON ALL MANHOLES IN PAVEMENT; VINYL OUTSIDE PAVEMENT.
5. COAT INTERIOR WITH TWO COATS OF COAL TAR EPOXY FOR A FINAL THICKNESS OF 21 MILS. WRAP OUTSIDE OF MANHOLE WITH WIDE WRAP MASTIC.
6. ALL MANHOLES WITHIN NCDOT ROW SHALL BE CONSTRUCTED PER NCDOT STANDARDS.



BRUNSWICK REGIONAL WATER AND SEWER H2GO

EFFECTIVE: APRIL 2022

**TYPICAL PRECAST MANHOLE**

STD. NO.

3000.05

NOT TO SCALE

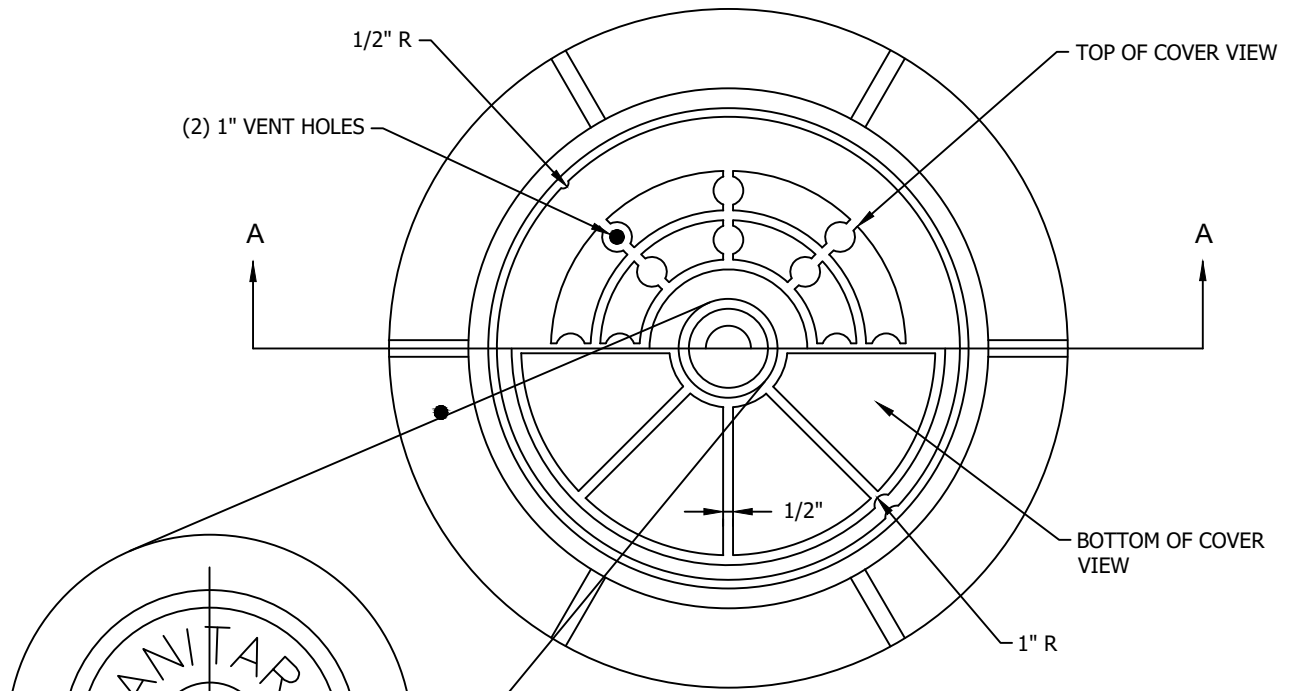

PLAN

**NOTE:**  
 FRAME AND COVER TO BE DEWEY BROS.,  
 INC. MH RCR-2001, MH RCR-2001W (FOR  
 SEALED MANHOLES IF REQ'D. - AS SHOWN  
 ON PLANS), OR APPROVED EQUAL

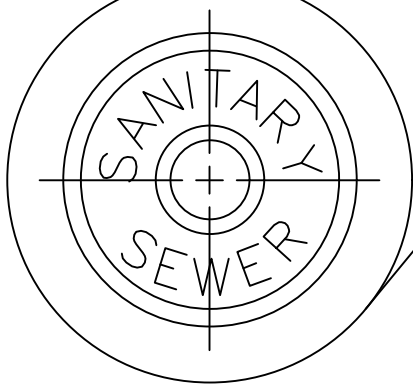

DETAIL

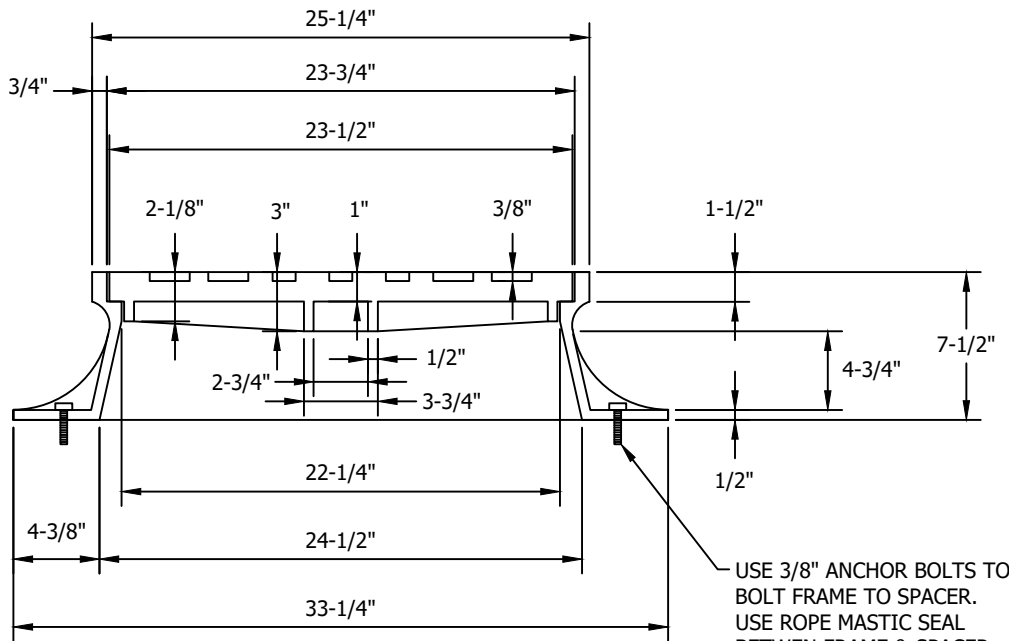

USE 3/8" ANCHOR BOLTS TO  
 BOLT FRAME TO SPACER.  
 USE ROPE MASTIC SEAL  
 BETWEEN FRAME & SPACER

SECTION A-A



BRUNSWICK REGIONAL  
 WATER AND SEWER H2GO

EFFECTIVE: APRIL 2022

STANDARD MH  
 FRAME AND COVER

STD. NO.

3000.06

NOT TO SCALE

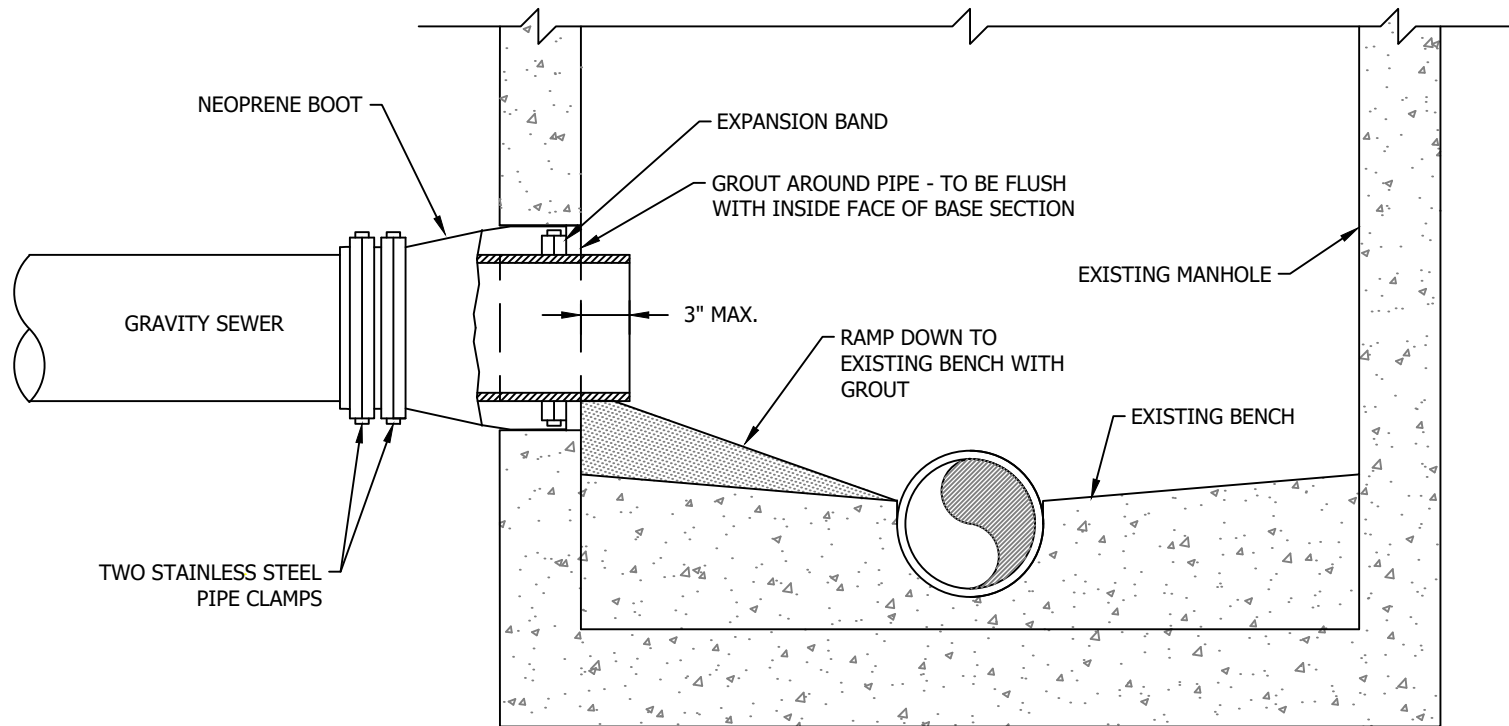

**NOTES:**

1. MATERIAL SPECIFICATIONS: NEOPRENE BOOT - ASTM C-923; PIPE CLAMP & EXPANSION CLAMP - STAINLESS STEEL, ASTM C-923.



BRUNSWICK REGIONAL  
WATER AND SEWER H2GO

EFFECTIVE: APRIL 2022

**STANDARD SEWER LINE CONNECTION  
TO EXISTING MANHOLE**

STD. NO.

3000.07

NOT TO SCALE



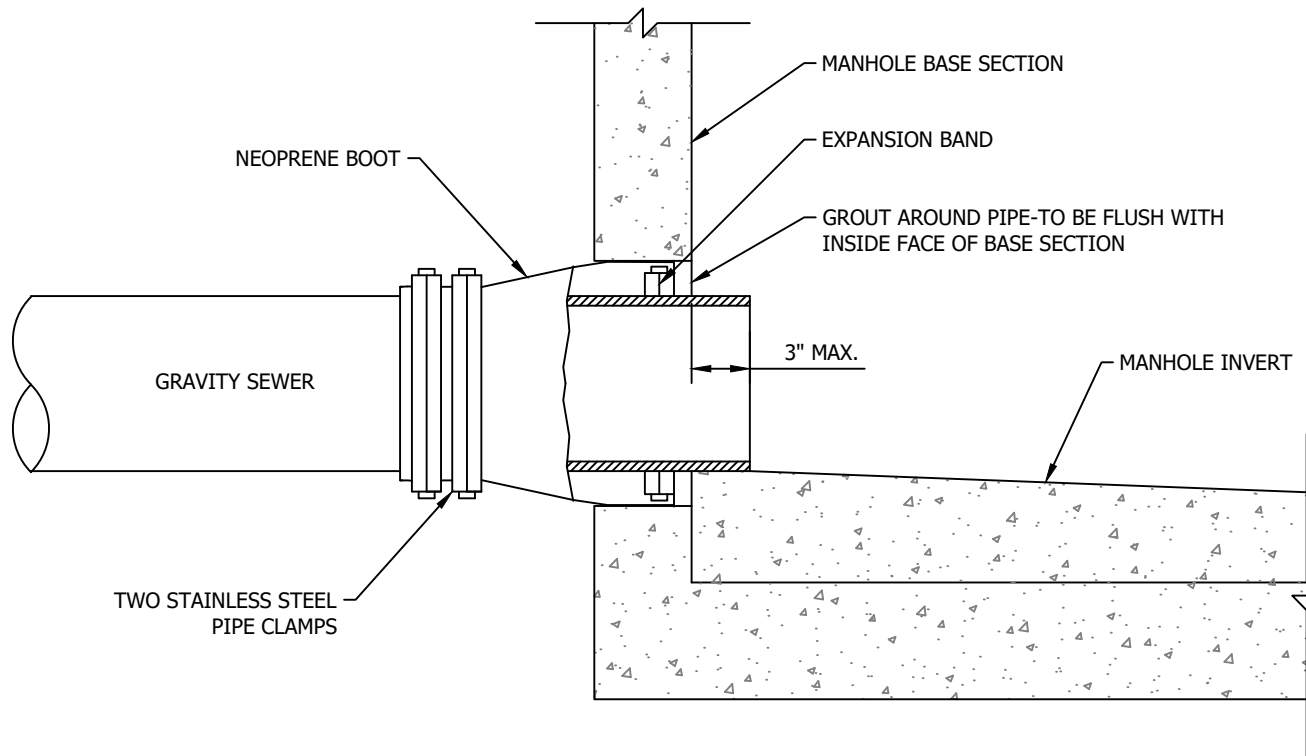

**NOTES:**

1. MATERIAL SPECIFICATIONS: NEOPRENE BOOT - ASTM C-923; PIPE CLAMP & EXPANSION CLAMP - STAINLESS STEEL, ASTM C-923.
2. TWO PIPE CLAMPS REQUIRED FOR PIPE O.D.'S 15" AND LARGER. TORQUE PER MANUFACTURER'S SPECIFICATIONS.
3. PIPE CLAMP (300-SERIES NON-MAGNETIC CORROSION-RESISTANT STEEL)



BRUNSWICK REGIONAL  
WATER AND SEWER H2GO

EFFECTIVE: APRIL 2022

# STANDARD MANHOLE BOOT

STD. NO.

3000.08

NOT TO SCALE

APS 120/220 SINGLE PHASE SIMPLEX, DEMAND DOSE CONTROL BOARDS. (ACCEPTABLE ALTERNATIVE)

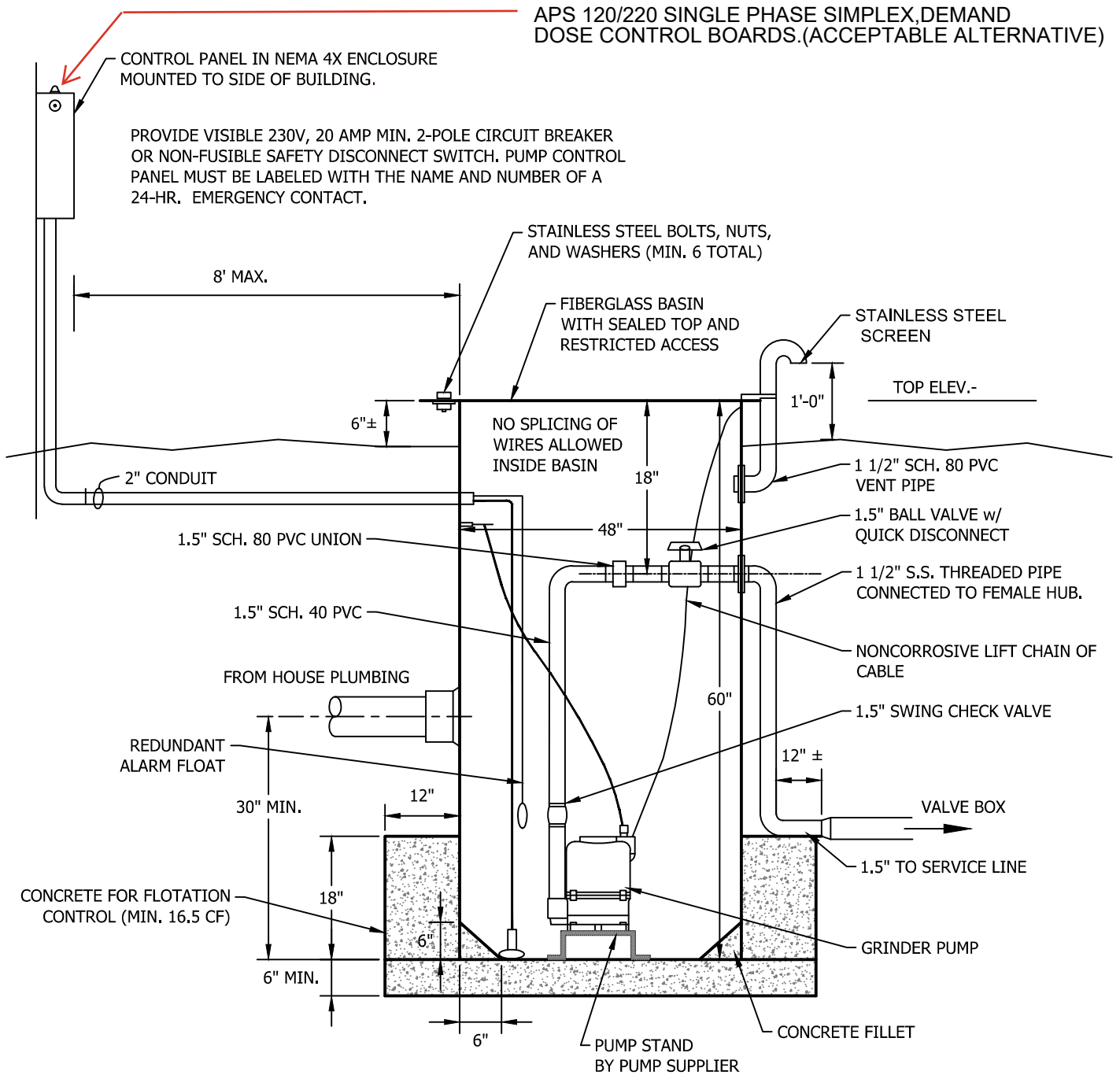

**NOTE:**

1. THE UNIT SHALL BE READILY ACCESSIBLE TO THE OWNER OR OWNER AGENT FOR EMERGENCY PURPOSES.
2. PUMP OFF LEVEL IS 12 INCHES FROM BOTTOM OF BASIN, PUMP ON LEVEL IS 20 INCHES FROM BOTTOM OF BASIN.
3. ALARM LEVEL IS 24' FROM THE BOTTOM OF THE BASIN.
4. A REDUNDANT ALARM FLOAT SHALL BE INCORPORATED INTO THE BASIN COMPONENTS.
5. TWO TYPES OF GRINDER PUMPS ARE CURRENTLY APPROVED FOR USE IN THE H2GO SERVICE AREA: COMPASS POINTE SERVICE AREA - ZOELLER E7020 PROGRESSING CAVITY GRINDER PUMP, SERVICE AREA OUTSIDE COMPASS POINTE - ZOELLER E7011 REVERSIBLE GRINDER PUMP.



BRUNSWICK REGIONAL WATER AND SEWER H2GO

EFFECTIVE: SEPTEMBER 2022

# HOUSE PUMPING UNIT

STD. NO.

3000.09

NOT TO SCALE

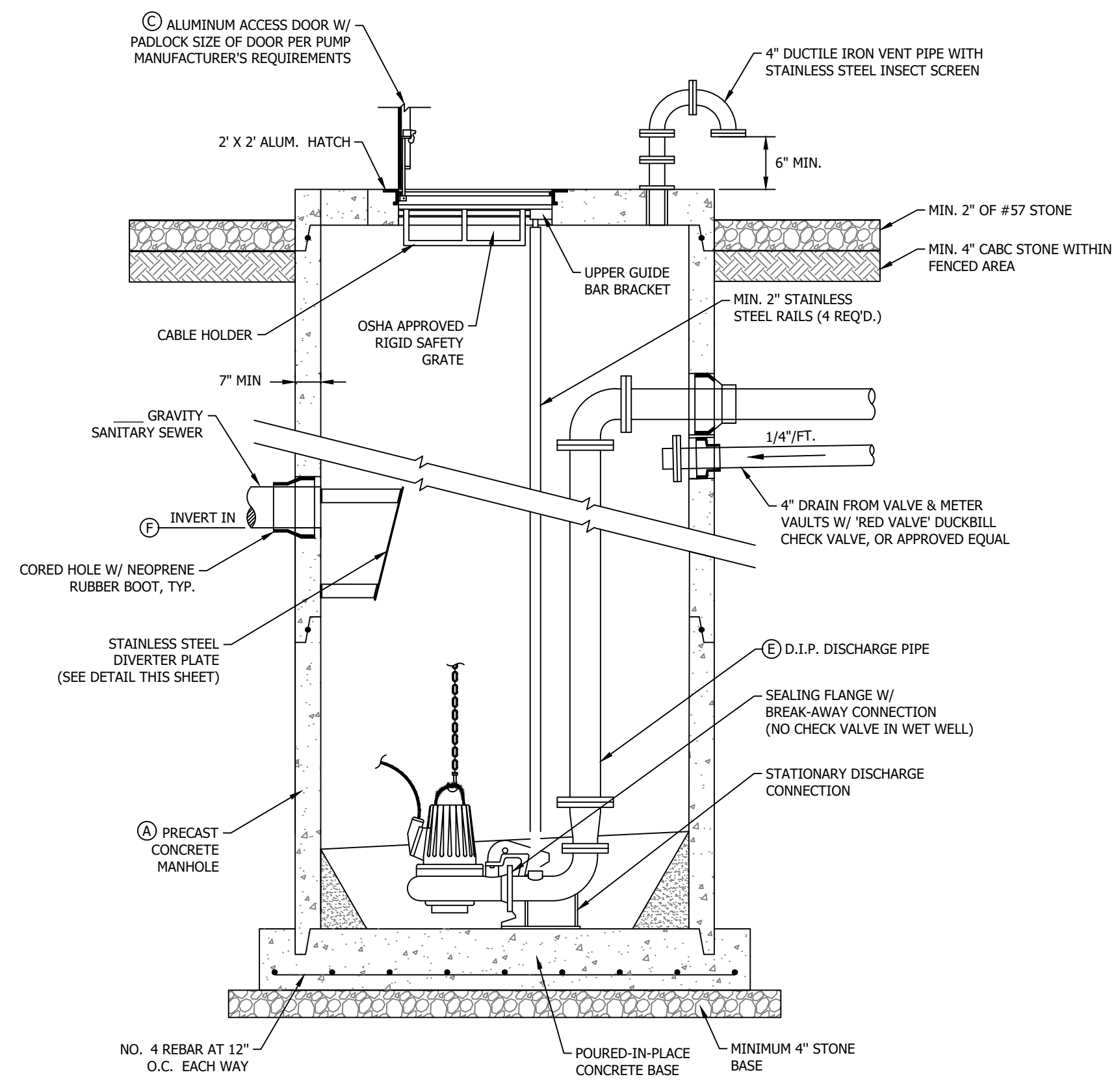

DUPLEX SUBMERSIBLE LIFT STATION - SECTION A-A

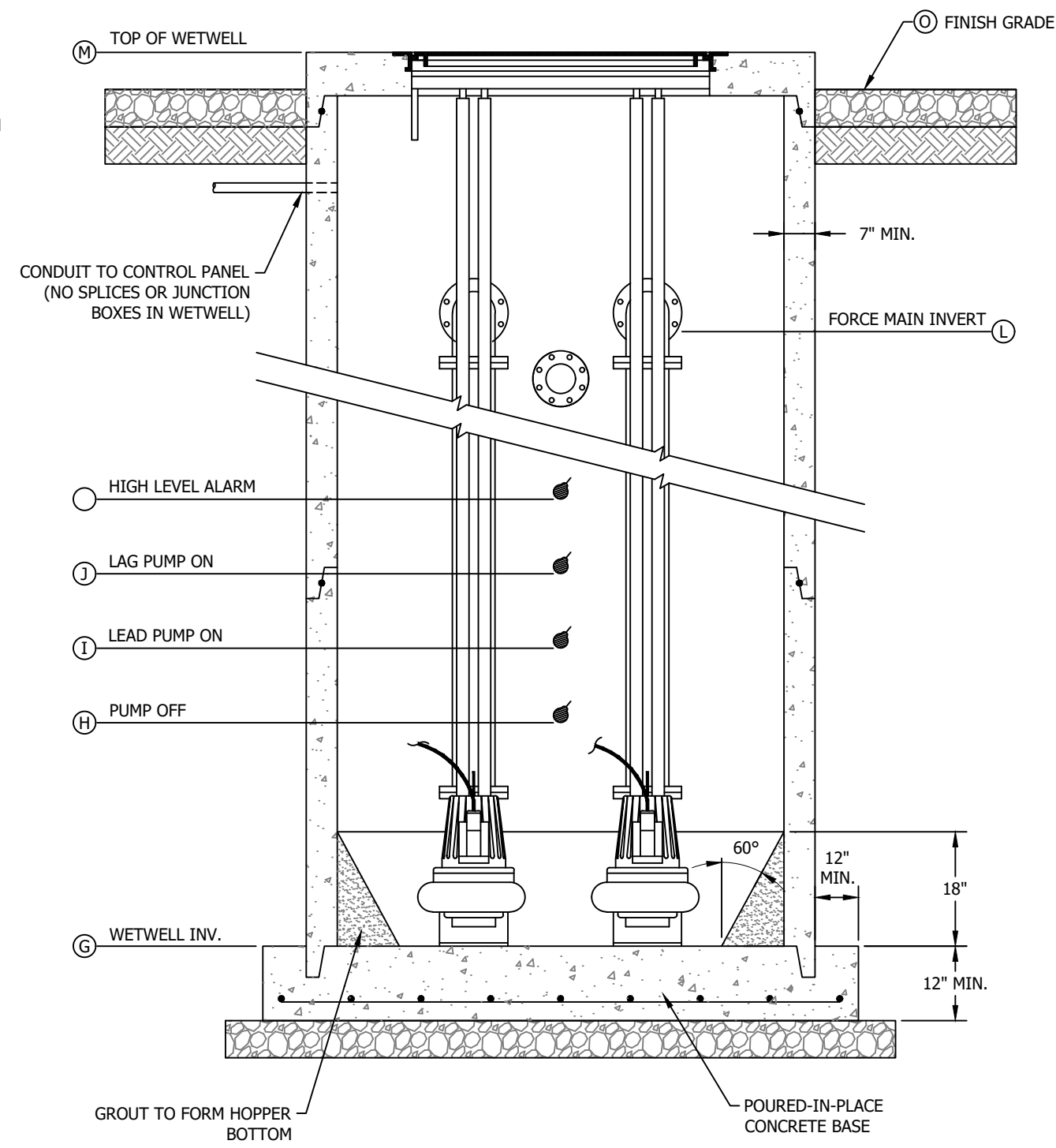

DUPLEX SUBMERSIBLE LIFT STATION - SECTION B-B

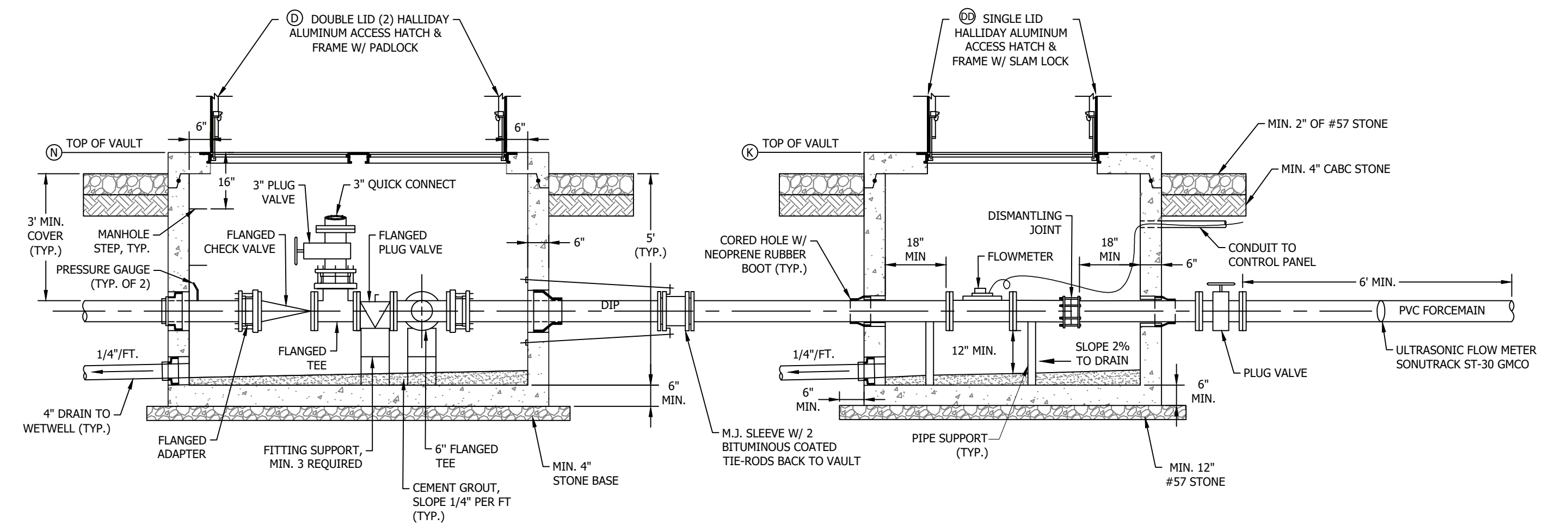

DUPLEX SUBMERSIBLE LIFT STATION - SECTION C-C

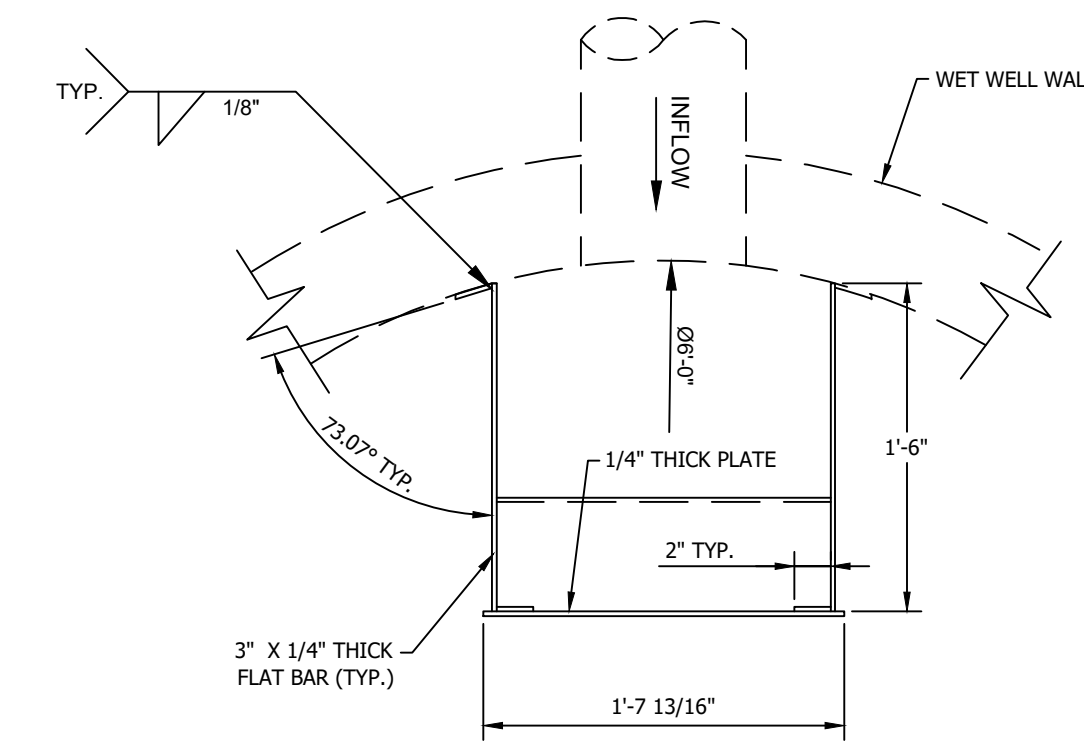

PLAN VIEW

- SPECIFICATION:
1. PLATE ASTM A340, T316L, STAINLESS STEEL
  2. FLAT BAR: ASTM A276, T316L, STAINLESS STEEL
  3. LINING/COATING: BARE
  4. QUANTITY: 2 EACH

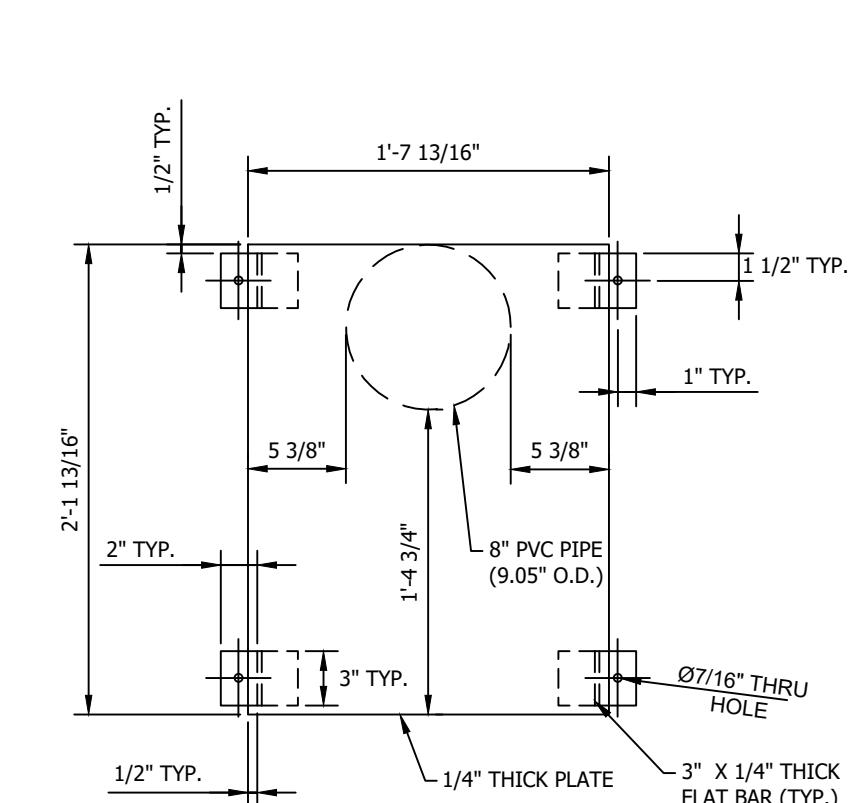

FRONT VIEW

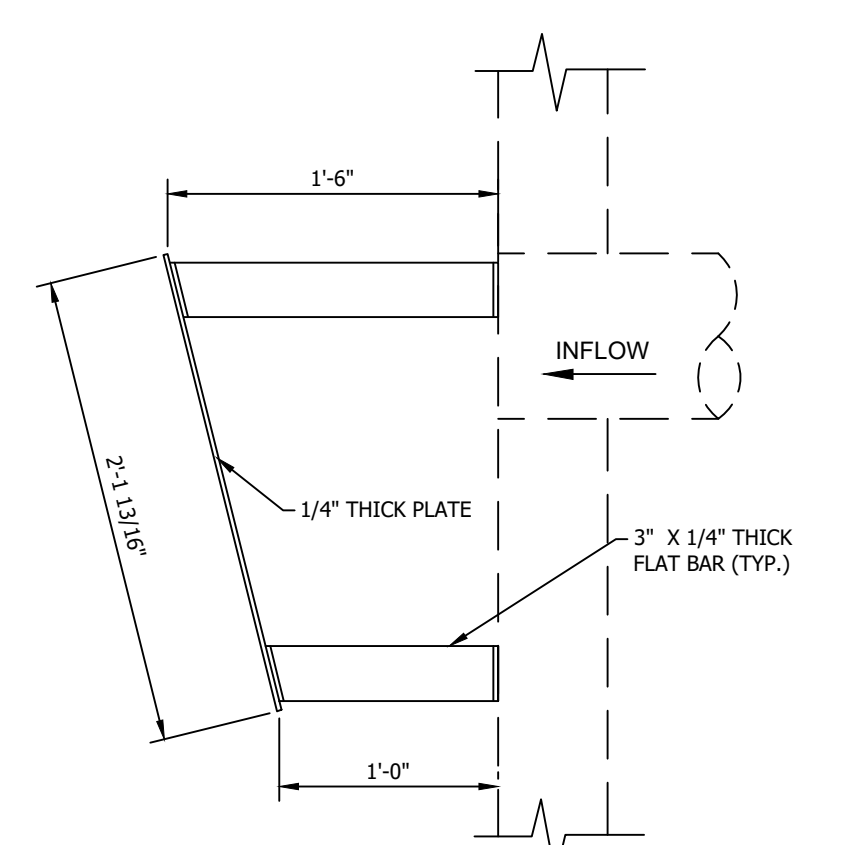

SIDE VIEW

DIVERTER PLATE

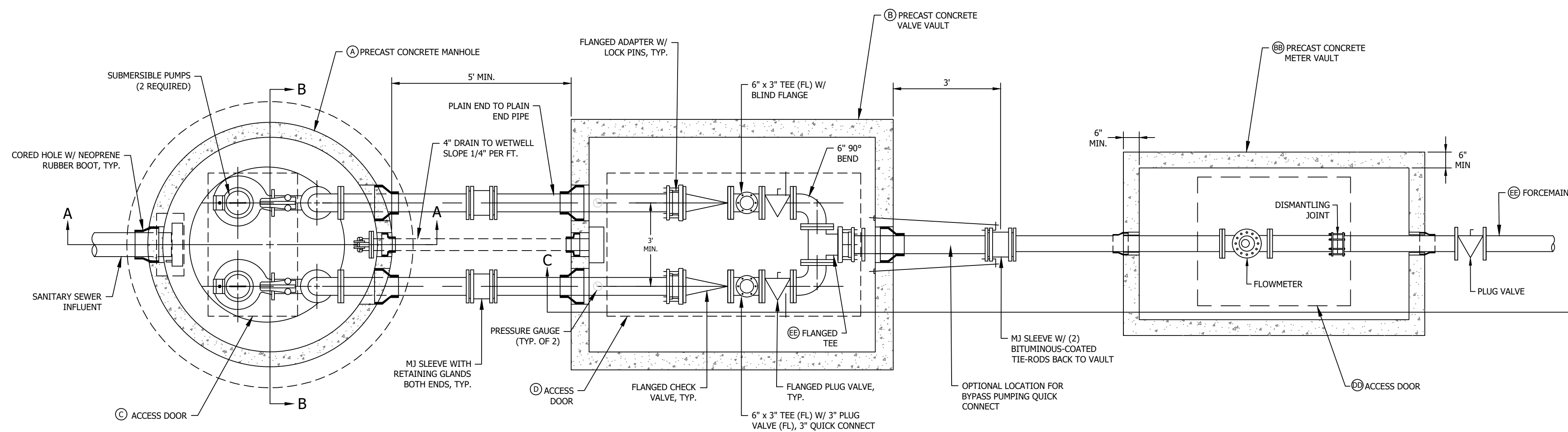

DUPLEX SUBMERSIBLE LIFT STATION - PLAN

GENERAL NOTES

1. (A) DENOTES A PUMP STATION DIMENSION/SIZE OR ELEVATION - SEE SCHEDULE.
2. ALL PUMP STATION PIPING IS FLANGED-END TO PLAIN-END (E)D.I.P., UNLESS NOTED OTHERWISE.
3. ALL FITTINGS INSIDE WET WELL, VALVE VAULT & METER VAULT TO BE FLANGED AND BITUMINOUS COATED, MINIMUM 1 MIL. THICK.
4. ALL PIPE OPENINGS IN WET WELL, VALVE VAULT & METER VAULT TO BE CORED AND FITTED WITH NEOPRENE RUBBER BOOTS.
5. VALVE VAULT & METER VAULT PIPING SHALL BE SUPPORTED WITH MASONRY OR STEEL SUPPORTS AT A MINIMUM OF 3 POINTS.
6. INSTALL A 1/4" TAP AND TEST COCK ON PIPING WITHIN VALVE VAULT.

DIMENSION SCHEDULE						
A (DIA)	B (WxL)	BB (WxL)	C (WxL)	D (WxL)	DD (WxL)	EE (DIA)

ELEVATION SCHEDULE (FT)										
F	G	H	I	J	K	L	M	N	O	

PUMP SCHEDULE				
PUMP STATION NUMBER	PUMP DISCHARGE DIAMETER	DESIGN CAPACITY (GPM)	DESIGN TDH (FT.)	VOLTAGE PHASE

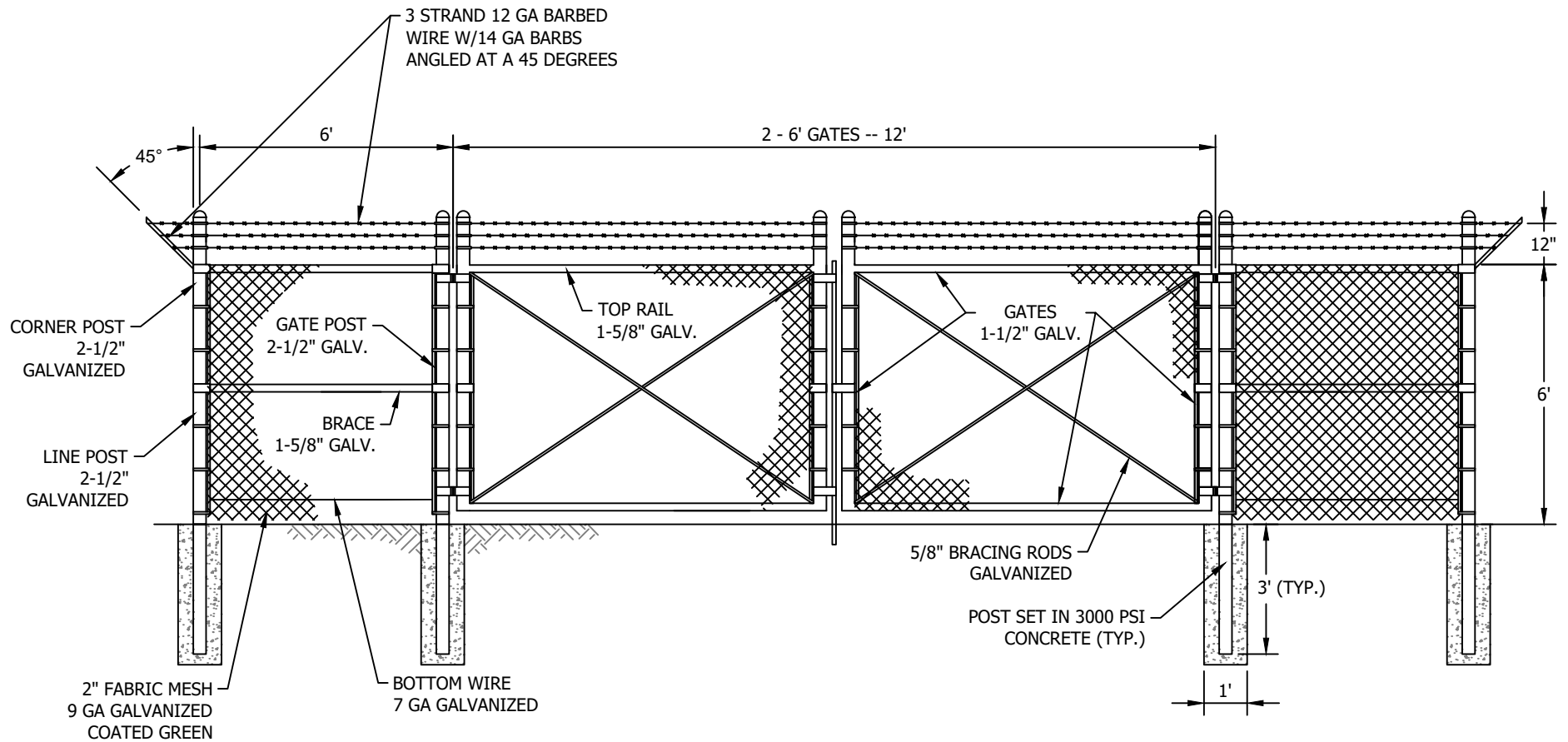

BRUNSWICK REGIONAL  
WATER AND SEWER H2GO

EFFECTIVE: APRIL 2022

# CHAINLINK FENCE

STD. NO.

3000.11

NOT TO SCALE

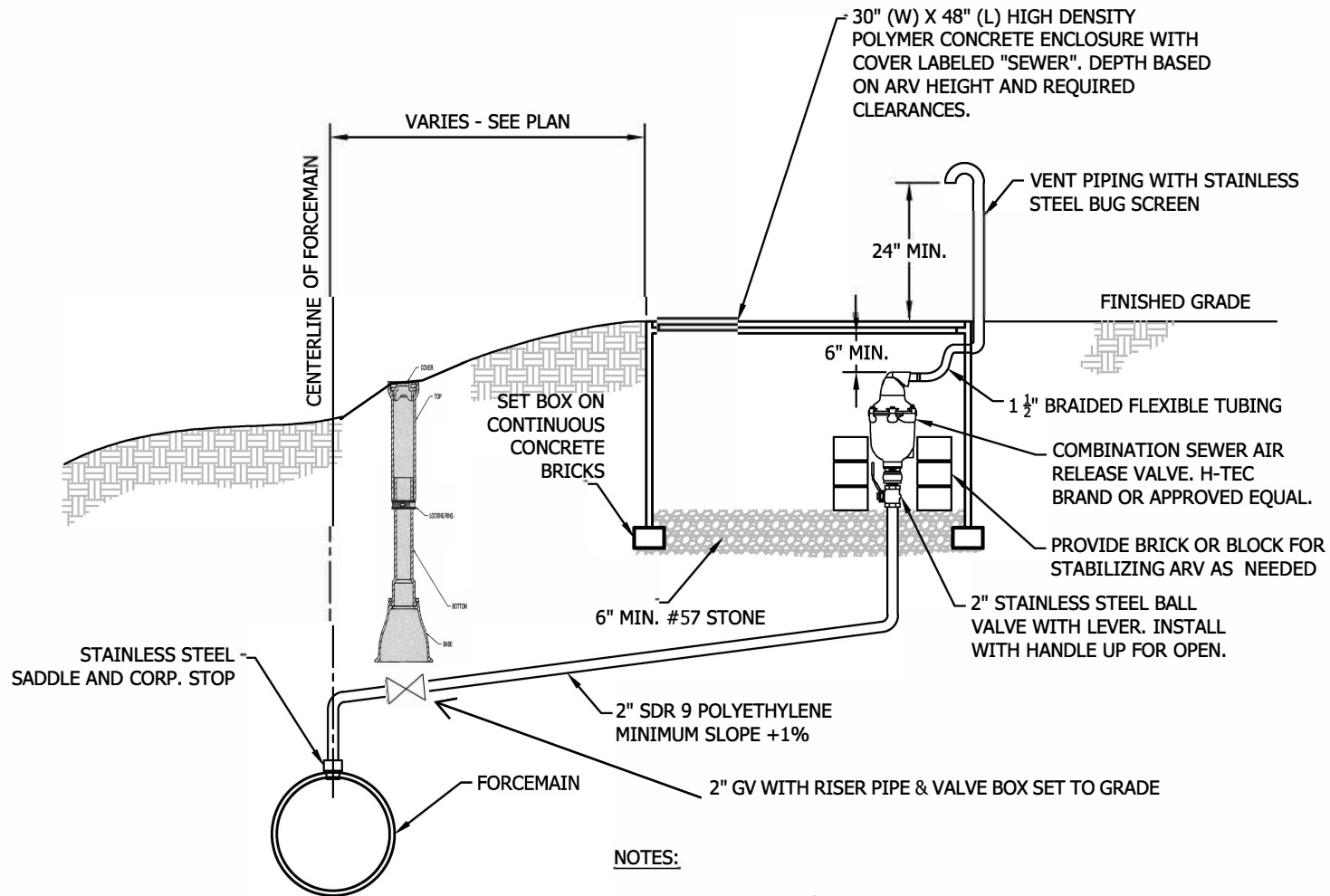

**NOTES:**

1. ROTATION AND LOCATION OF BOX TO BE APPROVED BY BRWS H2GO.
2. ARV ASSEMBLIES INSTALLED IN ROAD RIGHT-OF-WAY MUST BE FLUSH WITH EXISTING SHOULDER GRADE.
3. ARV ASSEMBLY SHOULD BE OFFSET TO ONE SIDE OF BOX AS SHOWN TO ALLOW EASIER ACCESS FOR OPERATION AND MAINTENANCE.
4. 2" STAINLESS STEEL NIPPLES AND COUPLINGS SHALL BE USED IF NEEDED.



**BRUNSWICK REGIONAL  
WATER AND SEWER H2GO**

EFFECTIVE: APRIL 2022

# OFFSET COMBINATION SEWER AIR RELEASE VALVE

STD. NO.

**3000.12**

NOT TO SCALE



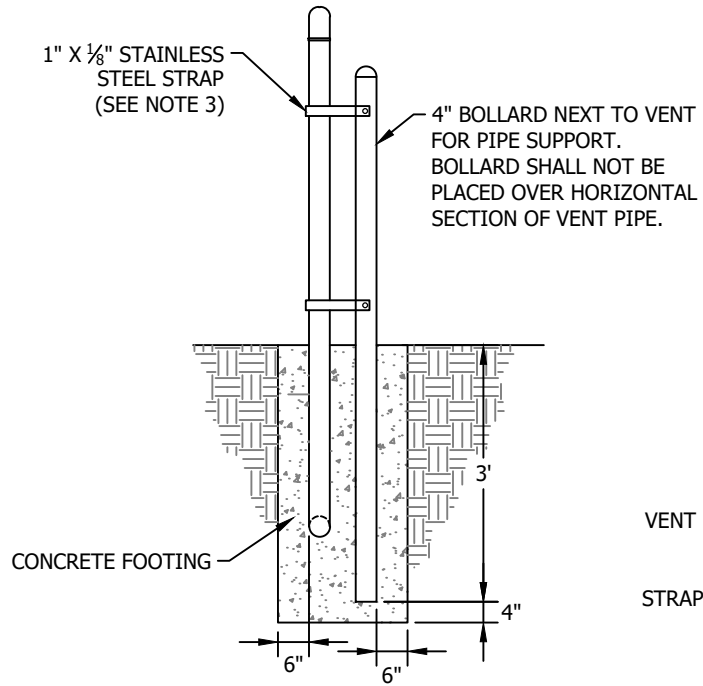

**BOLLARD SUPPORT**

VENT PIPING THAT CANNOT BE STRAPPED TO THE MANHOLE SHALL BE STRAPPED TO A 4" BOLLARD

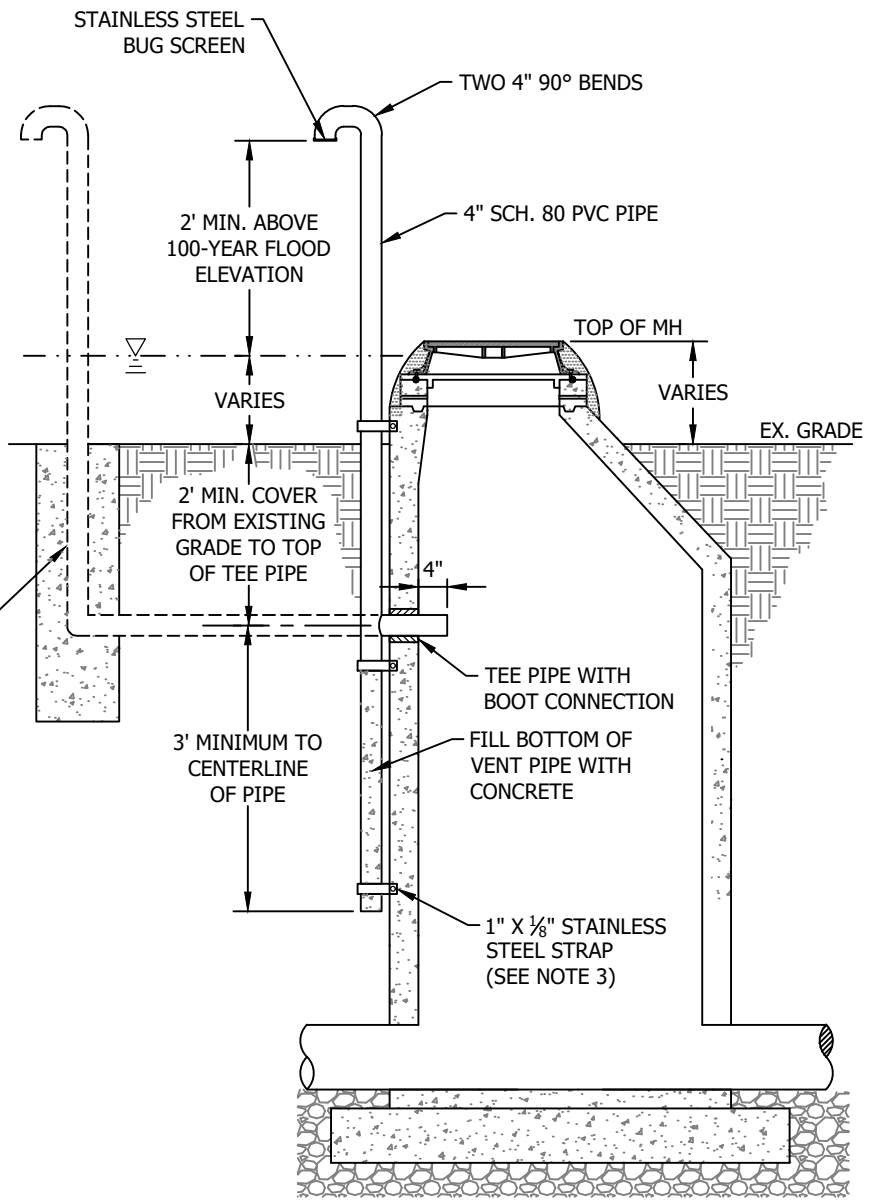

**NOTES:**

1. VENT PIPE OPENING IN PRECAST CONCRETE MANHOLE WALL SHALL BE CORED WITH A CONCRETE CORING MACHINE.
2. LOCATION OF VENT PIPE SHALL BE AS DIRECTED BY BRWS H2GO. VENTED MANHOLE SHALL HAVE WATERTIGHT RING AND COVER WITH VENT OPENING LOCATED AT LEAST 24 INCHES ABOVE THE 100-YEAR FLOOD PLAIN ELEVATION.
3. STRAP SPACING SHALL BE ONE EVERY 3 FEET WITH A MINIMUM OF 2 REQUIRED.
4. NEOPRENE BOOT, KOR-N-SEAL OR EQUAL, TO BE USED ON ALL PRECAST MANHOLES WITH ALL TYPES OF PIPES.



**BRUNSWICK REGIONAL WATER AND SEWER H2GO**

EFFECTIVE: JUNE 2022

**MANHOLE VENT**

STD. NO.

**3000.13**

NOT TO SCALE

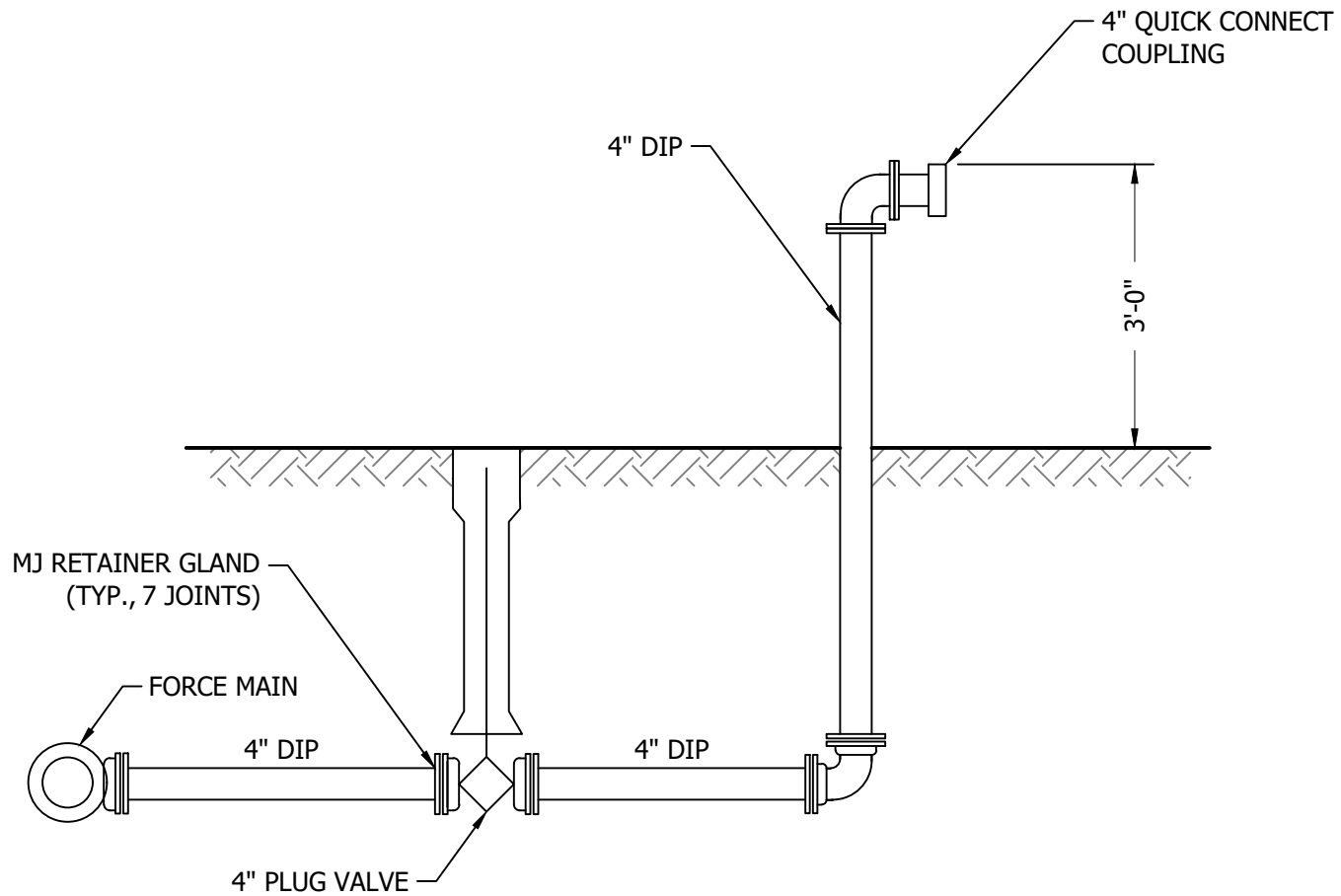

BRUNSWICK REGIONAL  
WATER AND SEWER H2GO

EFFECTIVE: APRIL 2022

## BYPASS PUMPING CONNECTION

STD. NO.

3000.14

NOT TO SCALE

**NOTES**

1. ALL TAPS WILL BE MADE IN ACCORDANCE WITH H2GO SPECIFICATIONS AND AWWA GUIDELINE "ANSI/AWWA C800-93" OR LATEST REVISION FOR TAPPING THROUGH POLYETHYLENE ENCASEMENT.
2. ALL MATERIAL TO COMPLY WITH H2GO SPECIFICATIONS.
3. TRACER WIRE SHALL BE INSTALLED FROM THE FORCEMAIN TO THE VALVE BOX.
4. THE HOMEOWNER IS RESPONSIBLE FOR THE GRAVITY CONNECTION FROM THE STRUCTURE TO THE GRINDER PUMP STATION AND FOR THE ELECTRICAL WIRING TO PROVIDE POWER TO THE PUMP PANEL.
5. SCHEDULE 40 PVC MAY BE USED IN LIEU OF CTS TUBING.
6. NEW SUBDIVSIONS INSTALLED BY CONTRACTOR TO BASIN.

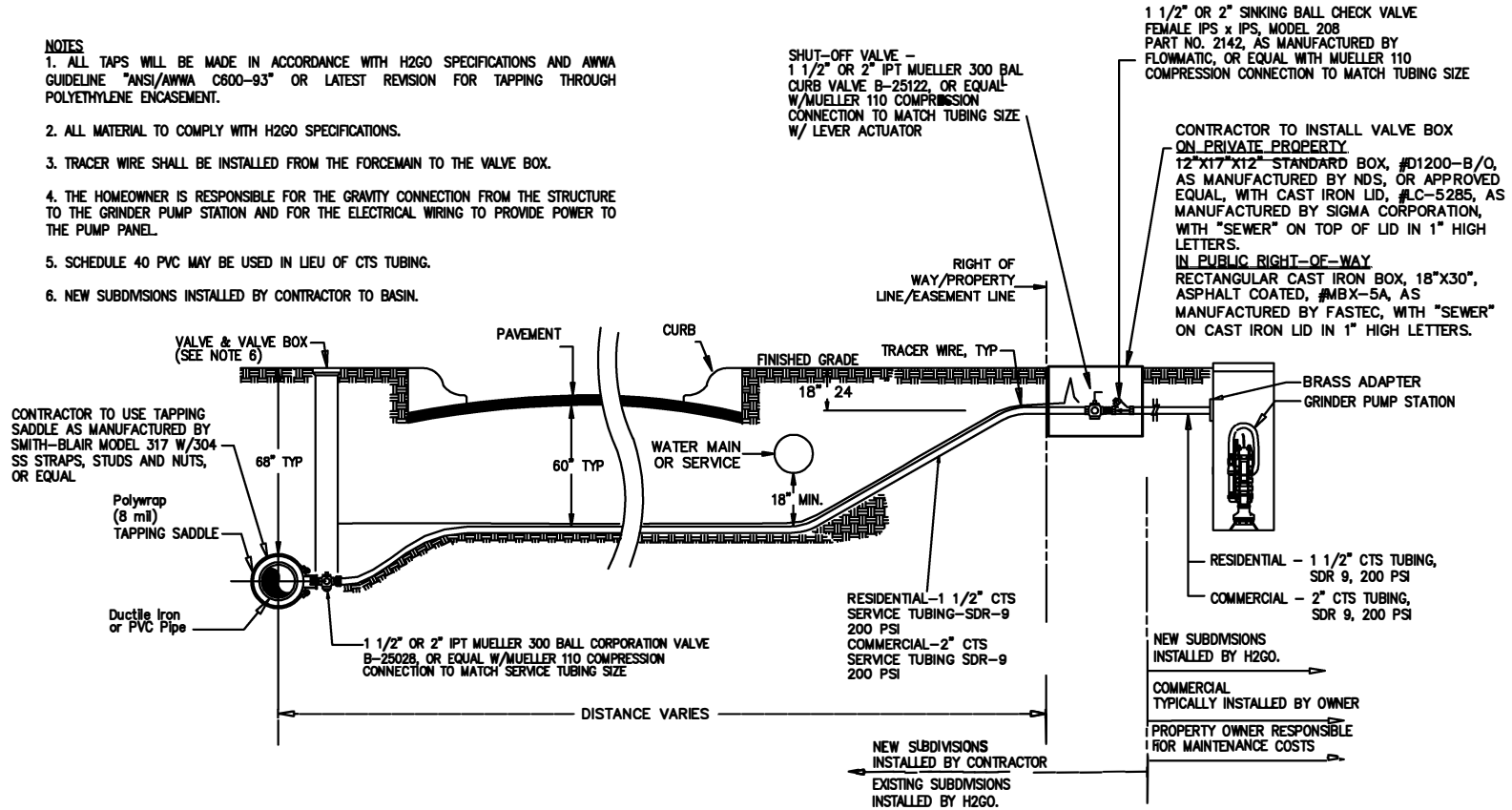

LOW PRESSURE SEWER CONNECTION.



BRUNSWICK REGIONAL  
WATER AND SEWER H2GO

Effective: September 2024

LOW PRESSURE SEWER CONNECTION

STD. NO.

3000.15

SHEET OF



PUMP STATION COMPONENTS	
A	WET WELL
B	VALVE VAULT - 6'x6'x6' MIN. (SEE NOTE 10)
C	METERING VAULT - 6'x6'x6' MIN. (SEE NOTE 12 & 19)
D	CONTROL PANEL (SEE DETAIL SHEET 3)
E	GENERATOR PAD AND STANDBY GENERATOR
F	AREA LIGHT ON POLE
G	ANTENNA PAD (SEE NOTE 9)
H	ODOR CONTROL PAD AND UNIT (SEE NOTE 15 & 18)
I	5" DIAMETER RECEIVING MANHOLE
J	EMERGENCY PUMP OUT
K	8" ABC (SEE DETAIL THIS SHEET)
L	INFLUENT SANITARY SEWER LINE
M	APPROVED BACKFLOW PREVENTION DEVICE
N	6" VENT
O	JUNCTION BOX RACK ASSEMBLY (SEE DETAIL)
P	2" IRRIGATION METER
Q	1" WATER SERVICE TO ODOR CONTROL UNIT
R	1" WATER SERVICE TO YARD HYDRANT
S	1" FREEZE-PROOF YARD HYDRANT
T	VENT PIPE TO ODOR CONTROL UNIT (SEE NOTE 15)
U	16" ALL-WEATHER GRAVEL DRIVE (SEE NOTE 5)
V	CHAIN LINK FENCE (SEE DETAIL)
W	DOUBLE SWING GATES 2 @ 7', TOTAL OPENING 14' (SEE DETAIL)

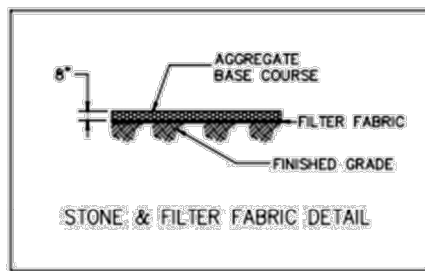

	REQUIRED	NOT REQUIRED
ODOR CONTROL UNIT		
METERING VAULT		

NOTE FOR ALL PUMP STATIONS:  
THE ODOR CONTROL SLAB, VENT PIPING FROM WETWELL, WATER SERVICE, AND ELECTRICAL CONDUIT FROM BUILDING OR ELECTRICAL RACK IS REQUIRED EVEN IF THE ODOR CONTROL UNIT IS NOT.

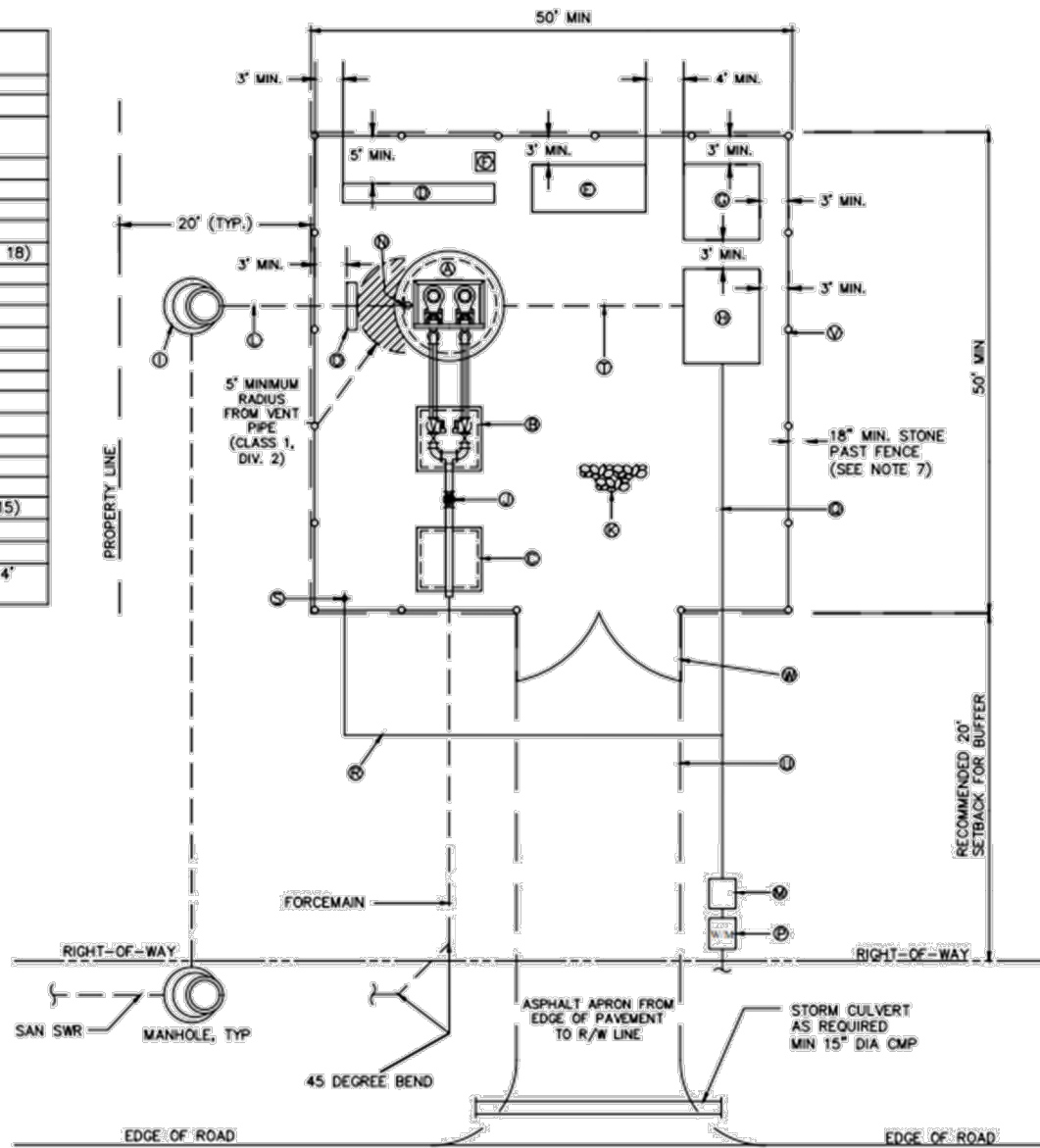

NOTES:

- NEW WET WELLS AND NEW RECEIVING MANHOLES ARE TO BE POLYURETE PER TECHNICAL SPECIFICATION 023.01. EXISTING WET WELLS INTERIOR TO RECEIVE MIN 120 MILS RAVEN 405 HIGH SOLIDS EPOXY OR APPROVED EQUAL FILTER OR APPROVED EQUAL.
- WET WELL VENT OUTLET TO HAVE ODORHOG CHARCOAL FILTER OR APPROVED EQUAL.
- THE PUMP STATION SITE SHALL BE A MINIMUM OF 50 FEET BY 50 FEET. THE PLAN HEREIN SHOWS A RECOMMENDED 20 FOOT BUFFER FROM THE PROPERTY LINE TO THE FENCED AREA. SEE APPLICABLE JURISDICTION'S ZONING ORDINANCE FOR REQUIRED BUFFERS.
- THE PUMP STATION SITE SHALL BE GRADED TO PROMOTE POSITIVE DRAINAGE AWAY FROM THE WET WELL. NO STORM DRAINAGE SHALL ENTER PUMP STATION SITE.
- THE ACCESS ROAD SHALL BE ABC STONE AT A MINIMUM 8" THICK. THE ROAD SHALL BE A MINIMUM OF 12' WIDE.
- THE ACCESS ROAD AND ENTIRE AREA WITHIN PUMP STATION FENCE SHALL BE A MINIMUM OF 2 FEET ABOVE THE 100 YEAR WATER SURFACE ELEVATION.
- THE PUMP STATION SHALL HAVE STONE EXTENDING 18" PAST THE FENCE LINE IN ALL DIRECTIONS.
- THE PUMP CONTROL PANEL MUST BE INSTALLED SUCH THAT IT FACES THE WET WELL.
- SEE ROHN ANTENNA DETAIL SHEET FOR ANTENNA DETAILS.
- VALVE VAULT MINIMUM SIZE IS 6'x6'x6'. ACTUAL REQUIRED MINIMUM SIZE DEPENDS ON ACTUAL DISCHARGE PIPING SIZES. ALL PIPING CONNECTIONS INSIDE VALVE VAULT SHALL BE EASILY ACCESSIBLE FOR MAINTENANCE AND REPAIR.
- NUT OPERATED PLUG VALVES IN VAULT MUST BE POSITIONED SO THAT THEY CAN BE OPERATED FROM ABOVE THE VAULT THROUGH THE HATCH WITH A STANDARD VALVE WRENCH.
- IF REQUIRED, METERING VAULT MINIMUM SIZE IS 6'x6'x6'. ACTUAL REQUIRED MINIMUM SIZE DEPENDS ON ACTUAL DISCHARGE PIPING SIZES. ALL PIPING CONNECTIONS INSIDE METERING VAULT SHALL BE EASILY ACCESSIBLE FOR MAINTENANCE AND REPAIR. IF A METERING VAULT IS REQUIRED, A SEPARATE METERING ENCLOSURE WILL BE REQUIRED. A DRAIN LINE WITH BACK FLOW TO THE WET WELL WILL BE REQUIRED.
- CONTRACTOR IS RESPONSIBLE FOR COORDINATING WITH ELECTRIC POWER COMPANY FOR PLACEMENT OF POWER COMPANY EQUIPMENT AND ANY REQUIRED CONCRETE SLABS, CONDUIT, ETC., NEEDED TO SERVE PUMP STATION. ELECTRIC COMPANY EQUIPMENT PLACEMENT SHALL NOT OBSTRUCT ACCESS DRIVE, GATES, GRAVITY SEWER MAIN, MANHOLES, DISCHARGE FORCE MAIN, OR ANY OTHER PUMP STATION EQUIPMENT.
- IF APPLICABLE, ODOR CONTROL UNIT REQUIREMENTS:
  - CONCRETE SLAB - 10'x8'x2". TO BE INSTALLED SO THAT 12" OF SLAB ARE ABOVE FINISHED GRADE.
  - INLET PIPE FROM WET WELL - 8" PVC MINIMUM
  - CORE AND BOOT WET WELL FOR 8" PVC VENT PIPE TO ODOR CONTROL UNIT.
  - SIEMENS WATER TECHNOLOGIES, ZABOCS MODEL 5000/6000 - CONTACT BRUNSWICK COUNTY PUBLIC UTILITIES FOR DETAILS
- ELECTRICAL POWER TO UNIT IS REQUIRED FROM ELECTRICAL RACK.
- WET WELL VENT IS CAPPED IF ODOR CONTROL UNIT IS UTILIZED.
- ALL PUMP STATION WORK BY CONTRACTOR SHALL BE OF ADEQUATE QUALITY AND WORKMANSHIP FOR ACCEPTANCE BY BRUNSWICK COUNTY.
- GENERATOR TO HAVE ENGINE EXHAUST SILENCER, WEATHER PROTECTIVE ENCLOSURE, AND SOUND ATTENUATION. REFER TO STANDBY EMERGENCY GENERATOR TECHNICAL SPECIFICATIONS FOR FURTHER DETAILS.
- ODOR CONTROL - SEE NOTE FOR ALL PUMP STATIONS THIS SHEET.
- IF BRUNSWICK COUNTY REQUIRES A FLOW METER (METER VAULT IS SHOWN), A METERING ENCLOSURE WILL BE REQUIRED. A 1.5" MIN. SCH. 80 PVC CONDUIT FROM THE METER VAULT TO THE METERING ENCLOSURE WILL ALSO BE REQUIRED.
- PROVIDE A MINIMUM OF 3 (THREE), 10' LONG, 3" DIAMETER, COPPER CLAD GROUND RODS SPACED A MINIMUM OF 20' APART, BONDED TOGETHER WITH INSPECTION WELLS AT EACH CONNECTION PER COUNTY DETAIL. ONE GROUND ROD AT:
  - ANTENNA TOWER
  - ELECTRIC METER
  - GENERATOR
- CONTRACTOR RESPONSIBLE FOR ALL BUILDING AND ELECTRICAL PERMITS NEEDED, INCLUDING SITE SPECIFIC ENGINEERED PLANS FOR GENERATOR PAD FOUNDATION.

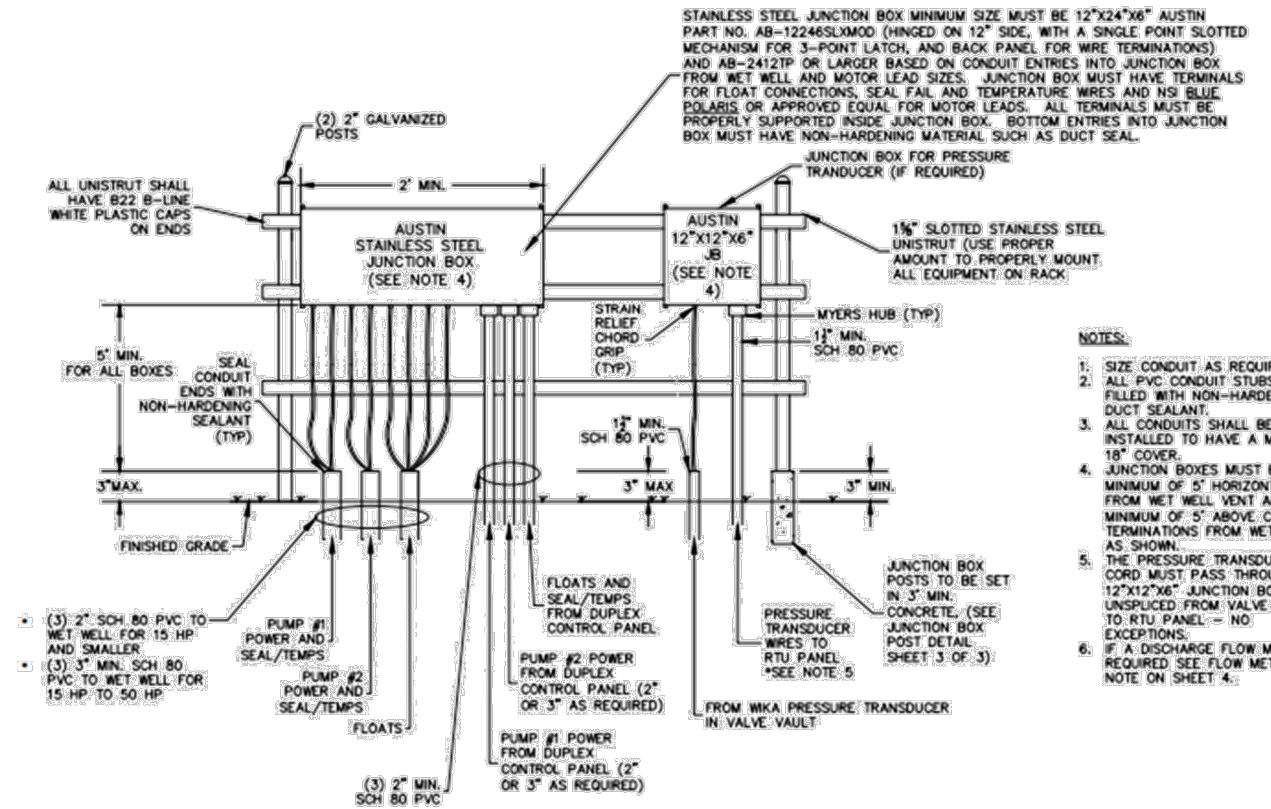

NOTES:

- SIZE CONDUIT AS REQUIRED.
- ALL PVC CONDUIT STUBS TO BE FILLED WITH NON-HARDENING DUCT SEALANT.
- ALL CONDUITS SHALL BE INSTALLED TO HAVE A MINIMUM 18" COVER.
- JUNCTION BOXES MUST BE A MINIMUM OF 5" HORIZONTAL FROM WET WELL VENT AND A MINIMUM OF 5" ABOVE CONDUIT TERMINATIONS FROM WET WELL AS SHOWN.
- THE PRESSURE TRANSDUCER CORD MUST PASS THROUGH THE 12"x12"x6" JUNCTION BOX UNSPLICED FROM VALVE VAULT TO RTU PANEL - NO EXCEPTIONS.
- IF A DISCHARGE FLOW METER IS REQUIRED SEE FLOW METER NOTE ON SHEET 4.



BRUNSWICK REGIONAL  
WATER AND SEWER H2GO

EFFECTIVE: OCTOBER 2022

PUMP STATION ELECTRICAL  
SITE & JUNCTION BOX DETAIL

STD. NO.

3000.16

SHEET 1 OF 1

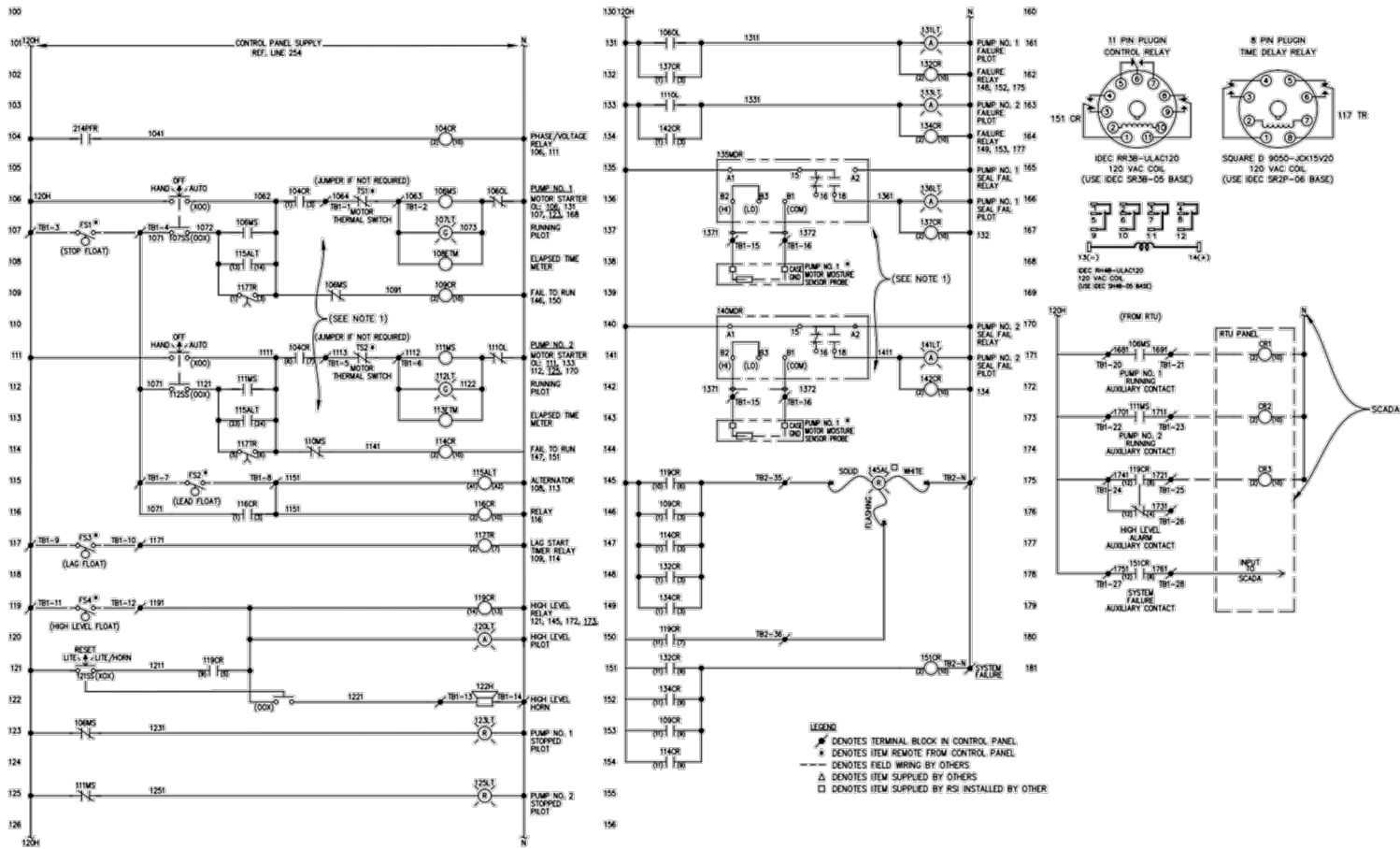

1-50 HP PUMP STATION ELECTRICAL DIAGRAMS

Float Detail

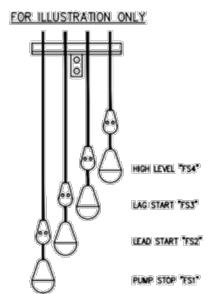

NOTES:  
 1. CONTROL CIRCUITRY SHOWN IS FOR A NON-FLYGT PUMP - DESIGN ENGINEER SHALL SUBMIT ELECTRICAL DRAWINGS FOR A FLYGT PUMP FOR BRUNSWICK COUNTY ENGINEERING AND UTILITIES DEPARTMENTS REVIEW AND APPROVAL.



BRUNSWICK REGIONAL WATER AND SEWER H2GO  
 EFFECTIVE: OCTOBER 2022

PUMP STATION ELECTRICAL DIAGRAMS

STD. NO.  
 3000.17  
 NOT TO SCALE





ITEM

A	SERVICE DISCONNECT (SEE NOTE 2)
B	AUTOMATIC TRANSFER SWITCH (SEE NOTE 2)
C	DUPLEX PUMP CONTROL PANEL (SEE NOTE 2 & 3)
D	RTU PANEL - FIBERGLASS
E	POLYPHASE COAXIAL CABLE SURGE ARRESTOR
F	COAX CABLE FROM ANTENNA
G	MINIMUM 3" GALVANIZED POSTS
H	GFCI PROTECTED OUTLET
I	DRY TRANSFORMER-10kVA (SEE NOTE 4)

NOTES:

- ALL POWER TO THE PUMP STATION SHALL BE THREE PHASE POWER. PUMP STATIONS 10 HP AND SMALLER MAY HAVE SINGLE PHASE POWER.
- TRANSFER SWITCH, DUPLEX PUMP PANEL, AND SERVICE DISCONNECT SHALL BE STAINLESS STEEL. THE DUPLEX PUMP PANEL SHALL HAVE A FACTORY APPLIED WHITE PAINT FINISH AND 3-POINT LOCKABLE HATCH.
- PROVIDE A MINIMUM OF THREE 10' LONG 3/4" DIAMETER COPPER CLAD GROUND RODS SPACED A MINIMUM OF 20' APART, EXOTHERMICALLY WELDED AND BONDED TOGETHER WITH INSPECTION WELLS AT EACH CONNECTION. ONE GROUND ROD LOCATED AT TOWER, ELECTRIC METER, AND GENERATOR.
- 10KVA DRY TRANSFORMER REQUIRED FOR 480 VAC PRIMARY.
- METER BASE, SCADA/RTU PANEL, AND FLOW METER ENCLOSURE (IF APPLICABLE) MAY BE MOUNTED ON THE BACK IF THERE IS NO ROOM ON THE FRONT. SERVICE DISCONNECT, ATS, AND PUMP CONTROL PANEL MUST BE MOUNTED TOGETHER ON THE FRONT AND FACE WET WELL.
- USE ADEQUATE AMOUNT OF 1 5/8" SLOTTED STAINLESS STEEL UNISTRUT TO SUPPORT ALL ENCLOSURES. EACH ENCLOSURE SHALL BE SUPPORTED BY A MINIMUM OF TWO HORIZONTAL PIECES OF UNISTRUT.
- ALL CONDUIT ENTRIES MUST PENETRATE THE BOTTOM OF ALL ENCLOSURES WITH MYERS HUB TYPE FITTINGS, NO EXCEPTIONS. NO CONDULET FITTINGS (LL, LB, OR LR) ALLOWED.
- ALL CONDUIT SHALL BE SCHEDULE 80 PVC.
- ALL ENCLOSURE LABELS SHALL BE OUTDOOR VINYL LABELS AND SHALL BE MOUNTED TO THE ENCLOSURE WITHOUT ANY DRILLING OF THE ENCLOSURE.
- ALL POWER WIRES AND CONTROL WIRES MUST BE PROPERLY AND PERMANENTLY LABELED ON BOTH ENDS OF WIRES, NO EXCEPTIONS.
- INSTALL NON-HARDENING DUCT SEALANT ON ALL CONDUIT ENTRIES IN EVERY ENCLOSURE.

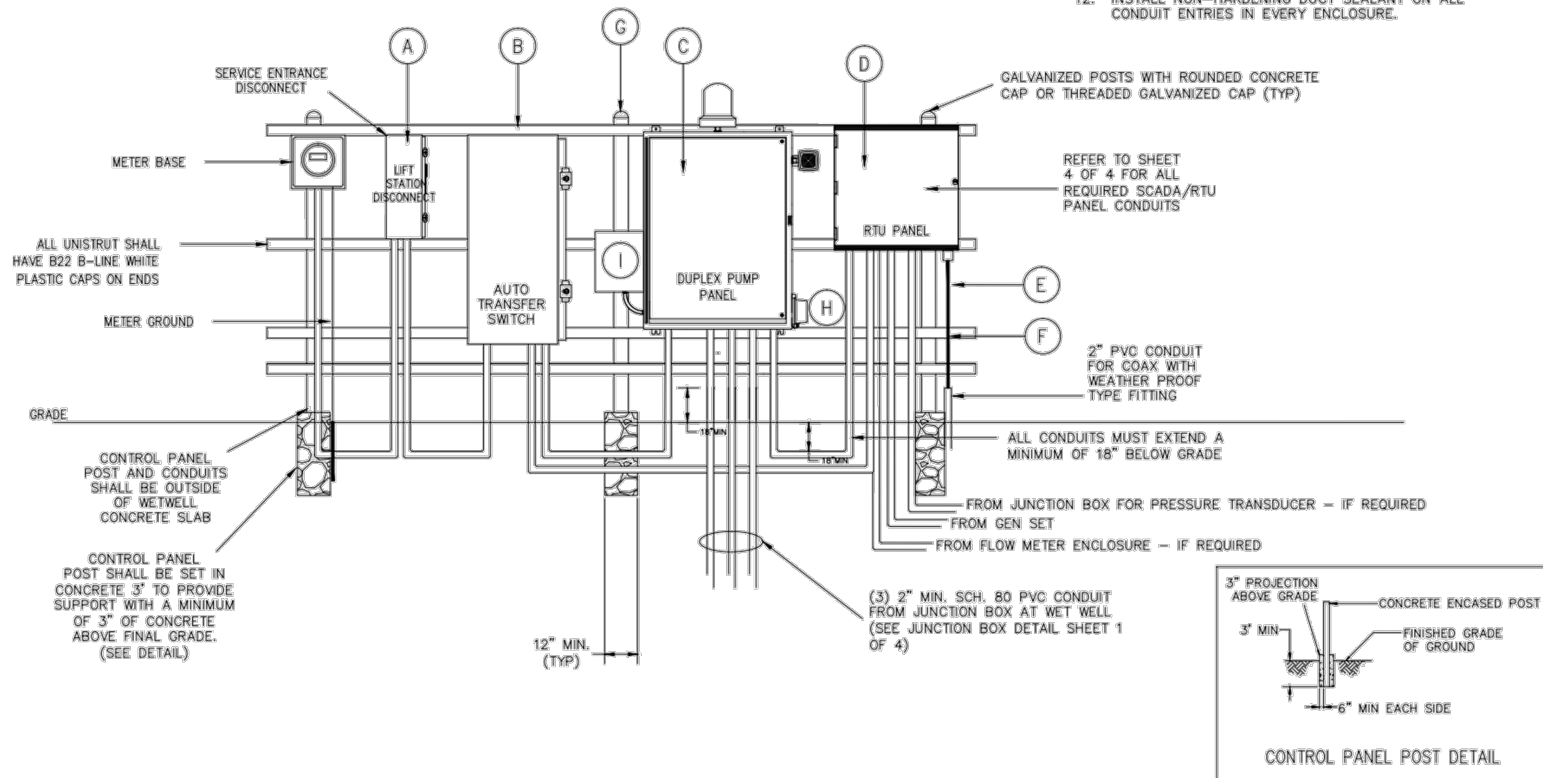

BRUNSWICK REGIONAL  
WATER AND SEWER H2GO

EFFECTIVE: OCTOBER 2022

# PUMP STATION ELECTRICAL CONTROL PANEL ELEVATION

STD. NO.

3000.19

NOT TO SCALE

200 INCOMING POWER  
(SEE NOTE 7)  
480VAC 3-PHASE, 60HZ, \_\_\_\_\_AMPS (MIN. SERVICE SIZE IS 100 AMPS)

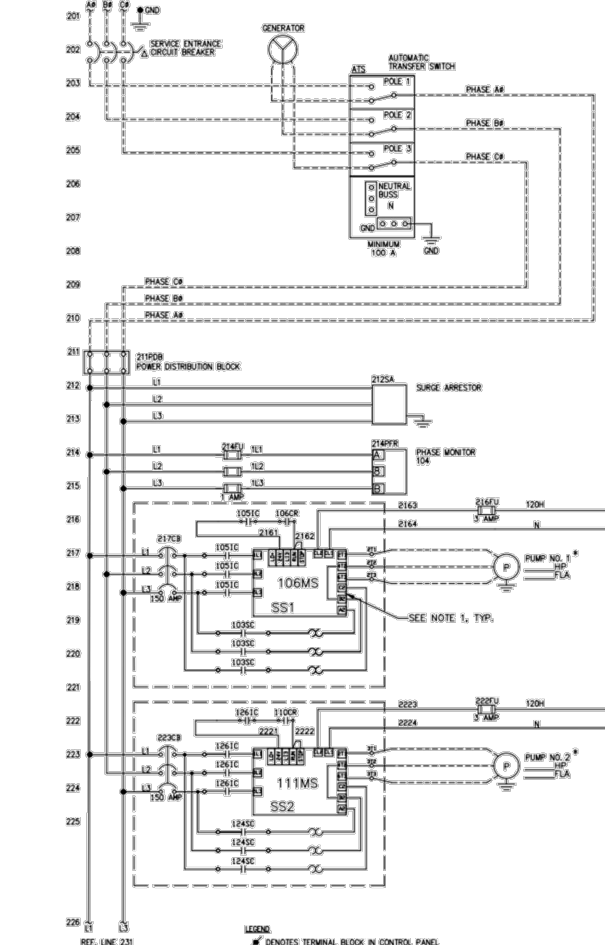

**LEGEND**  
 # DENOTES TERMINAL BLOCK IN CONTROL PANEL  
 # DENOTES ITEM REMOTE FROM CONTROL PANEL  
 --- DENOTES FIELD WIRING BY OTHERS  
 Δ DENOTES ITEM SUPPLIED BY OTHERS  
 □ DENOTES ITEM SUPPLIED BY RSI INSTALLED BY OTHER

**1-50 HP PUMP STATION  
ELECTRICAL DIAGRAMS**

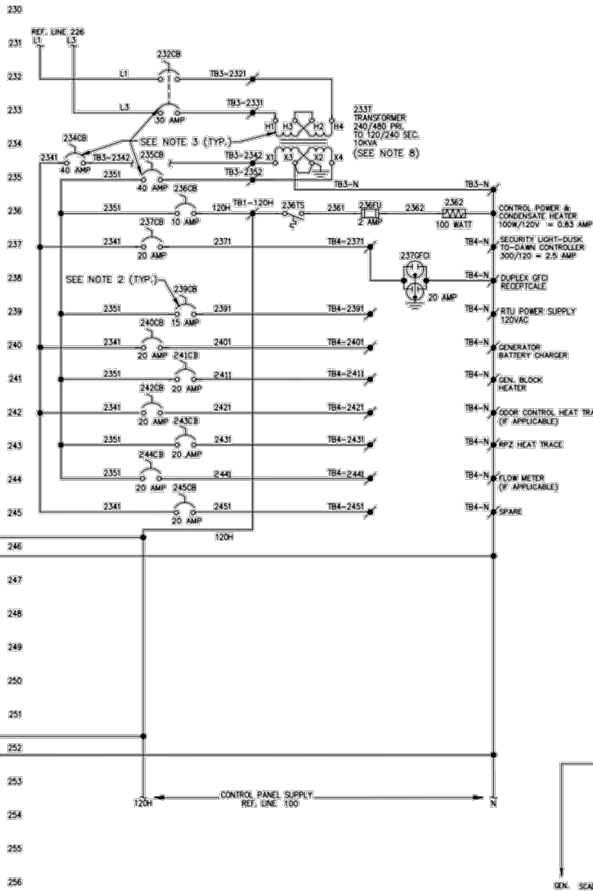

**SCADA/RTU PANEL CONDUIT SCHEDULE**  
(ALL CONDUIT TO BE SCH 80 PVC)

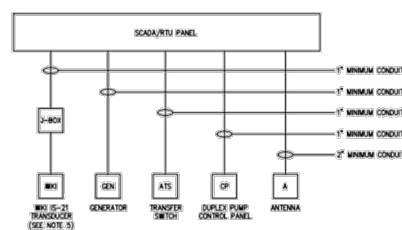

- NOTES:**
- STARTING DEVICE SHOWN IS A REDUCED VOLTAGE SOLID STATE STARTER. STARTING DEVICE MAY BE A FULL VOLTAGE NON-REVERSING STARTER, A REDUCED VOLTAGE SOLID STATE STARTER, OR A VARIABLE FREQUENCY DRIVE DEPENDING ON THE SITUATION AND THE NEEDS OF THE PUMP STATION. LOCATE STARTING DEVICES OUTSIDE OF THE PUMP CONTROL PANEL WHERE APPROVED BY BRUNSWICK COUNTY. TYPICALLY FOR LARGER HORSEPOWER DESIGNS, STARTING DEVICES LOCATED OUTSIDE OF THE PUMP CONTROL PANEL SHALL BE LOCATED IN THEIR OWN ENCLOSURES. ENCLOSURES SHALL HAVE SUITABLE NEMA RATINGS FOR THE ENVIRONMENT THEY ARE LOCATED IN, AND SHALL BE APPROVED BY BRUNSWICK COUNTY ENGINEERING AND UTILITIES.
  - ADD ADDITIONAL CIRCUIT BREAKERS IN THE PUMP CONTROL PANEL WHERE NECESSARY TO ACCOMMODATE ADDITIONAL LOADS.
  - ADJUST THE SIZE OF THE TRANSFORMER AND CIRCUIT BREAKERS AS NECESSARY TO ACCOMMODATE ANY INCREASE IN THE MISCELLANEOUS LOAD.
  - PUMP MOTORS 10HP AND SMALLER CAN BE SINGLE PHASE POWER.
  - IF A WIKI IS-21 PRESSURE TRANSDUCER IS INSTALLED IN THE PUMP STATION VALVE VAULT, A MINIMUM 1" PVC CONDUIT MUST BE INSTALLED FROM THE VALVE VAULT TO J-BOX, THEN FROM THE J-BOX TO THE RTU/SCADA PANEL (OR TO THE ELECTRICAL BUILDING IF THE PUMP STATION HAS AN ELECTRICAL BUILDING).
  - PUMPS 10 HP AND SMALLER MAY BE SINGLE PHASE POWER.
  - DESIGN ENGINEER TO SPECIFY INCOMING POWER VOLTAGE, PHASE, AND AMPERES (MINIMUM SERVICE SIZE IS 100 AMPERES).
  - TRANSFORMER REQUIRED FOR 480 VAC PRIMARY PUMP STATIONS.
  - IF ODOOR CONTROL UNIT IS INSTALLED, AN ADDITIONAL 480VAC, 3 PHASE, 15 AMP CIRCUIT BREAKER IS REQUIRED.

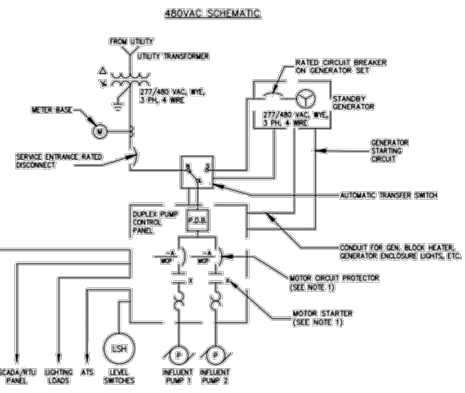

MOTOR HP	NEMA RATING	MCP
1-10HP	1	3-30A
10-25HP	2	30-50A
25-50HP	3	50-100A
50-100HP	4	100-400A



**BRUNSWICK REGIONAL  
WATER AND SEWER H2GO**  
EFFECTIVE: OCTOBER 2022

**PUMP STATION ELECTRICAL  
SCHEMATICS**

STD. NO.  
**3000.20**  
NOT TO SCALE

BILL OF MATERIAL				
ITEM	QTY.	MANUFACTURER AND CATALOG NUMBER	DESCRIPTION	
1	1	HOFFMAN A-48D612SLP 3PT	ENCLOSURE, NEMA 4K, STAINLESS STEEL, 48"X 36"X 12" MINIMUM, FACTORY WHITE PAINT, 3-POINT LATCHES	
1	1	HOFFMAN A-48P36	PANEL, 48"X 33"X 3"	
1	1	HOFFMAN A-NADR	INNER DOOR KIT	
1	1	HOFFMAN CUSTOM	SHING-OUT PANEL, ALUMINUM, 44"X 33"X 3"	
2	2	SQUARE D 8536-SD01W2H10	FULL VOLTAGE STARTER, SIZE #, * POLE, 120 VAC COIL, SOLID STATE THERMAL OVERLOAD, CLASS 10 TRIP, 15-45 AMP	
2	2	SQUARE D 9999-SX8	AUXILIARY CONTACT, 1 N.O. & 1 N.C. CONTACT	
2	2	SQUARE D 9066-R41	MOTOR STARTER RESET BUTTON/MECHANISM	
2	2	SQUARE D 9999-A04	AUXILIARY CONTACT FOR OVERLOAD	
2	2	SQUARE D 9999-SX7	AUXILIARY CONTACT 1-N.C.	
3	3	SQUARE D 9001-SKSA3BH1	SELECTOR SWITCH, 3 POSITION, NEMA 4X, CONTACT BLOCK, 1 N.O. & 1 N.C. CONTACT	
1	1	SQUARE D 9001-KA1	CONTACT BLOCK, 1 N.O. & 1 N.C.	
4	2	SQUARE D 9001-SKP1G31	PILOT LIGHT, NEMA 4X, TRANSFORMER TYPE, 120 VAC, GREEN LENS	
5	2	SQUARE D 9001-SKP1R31	PILOT LIGHT, NEMA 4X, TRANSFORMER TYPE, 120 VAC, RED LENS	
6	5	SQUARE D 9001-SKP1A31	PILOT LIGHT, NEMA 4X, TRANSFORMER TYPE, 120 VAC, AMBER LENS	
7	1	SQUARE D 00U 110	CIRCUIT BREAKER, 1 POLE, 10 AMP, 125 VOLT	
8	8	IECC 9H38-LLAC120	CONTROL RELAY, 4PDT, BLADES, INDICATING LIGHT, 120V COIL, 11 PIN RELAY SOCKET, 11 BLADES, DIN RAIL MOUNT	
8	8	IECC 9H38-05		
9	1	SQUARE D FK7GTA	GROUND BAR	
10	1	SQUARE D CA29KE2007	ALTERNATION RELAY, 120 VOLT, 2 N.O. CONTACTS	
12	2	TELEMECANIQUE RM4L02IF	SEAL FAIL RELAY	
13	A/R	PANDUIT TYPE F	WIRE DUCT, GREY, NON-SLIP COVER (REFER TO DIMENSIONS ON LAYOUT)	
14	39	WEDMELLER 102010000	TERMINAL BLOCKS, 600 V, 35 AMPS, TYPE M0U 4, #10-#22 AWG WIRE	
15	1	EDWARDS 976-N5	ALARM HORN, 120VAC, NEMA 4K	
16	2	ENI 1508212	COUNTER, 120VAC, 6 1/2 DIGIT	
17	1	SQUARE D 9050-JK15V20	TIMER RELAY, 2PDT, 10 AMP, 8 PIN BASE, 120 VAC 60HZ COIL	
1	1	IECC 9R2P-06	RELAY SOCKET, 8 PINS, DIN RAIL MOUNT	
18	1	MOTOR SAVER 460-14	PHASE FAILURE RELAY, 3 PH, 480VAC	
19	1	BUSSMANN BM6033PQ	FUSEBLOCK	
3	3	BUSSMANN FNM-1	FUSE, 1 AMP, 600V, TIME DELAY TYPE	
20	1	EDWARDS 102PM85-N5	PIPE MOUNT BASE	
2	2	EDWARDS 102LM-R	LENS MODULE - RED	
1	1	EDWARDS 102LS-ST-N5	STROBE LIGHT SOURCE	
1	1	EDWARDS 102LS-SB-N5	STEADY ON, INCANDESCENT LIGHT SOURCE	
21	1	SQUARE D 505A3650	SURGE ARRESTOR, 600 VOLT, 3 PHASE, W/ LED INDICATOR	
22	1	SQUARE D 9080-LB363104	DISTRIBUTION BLOCK, 600 VOLT, 3 POLE, MAIN (1) #6-400 AWG, BRANCH (4) #14-2 AWG	
23	1	HEATREX 276-1	HEATER, 120 VAC, 150 WATT WITH FINGER GUARD	
24	1	HOFFMAN ATEMNC	THERMOSTAT, SPST, CLOSE ON FALL, 30-140 DEG.	
25	1	BUSSMANN BM6033PQ	FUSE BLOCK, 600 VOLT, 1 POLE, 30 AMP	
1	1	BUSSMANN FNM-2	FUSE, 2 AMP, 250V, TIME DELAY TYPE	
26	7	SQUARE D 00U 120	CIRCUIT BREAKER, 1 POLE, 20 AMP, 125 VOLT	
27	1	SQUARE D 00U 115	CIRCUIT BREAKER, 1 POLE, 15 AMP, 125 VOLT	
28	2	SQUARE D FAJ3603015M	MOTOR CIRCUIT PROTECTOR, * POLE, * AMP, MAGNETIC TRIP, CIRCUIT BREAKER	
29	4	WEDMELLER 102030000	TERMINAL BLOCKS, 600 V, 65 AMPS, TYPE M0U 10, #6-#18 AWG WIRE	
30	1	SQUARE D 7400-1051F	TRANSFORMER, *P/*-/*V VOLT, 10 KVA, DRY TYPE, NEMA 3R (SEE NOTE #2)	
31	1	SQUARE D FAJ24030	CIRCUIT BREAKER, * POLE, * AMP, * VOLT, FEED TO KVA TRANSFORMER	
32	1	PASS & SEYMOUR WUCASTI	DUPLEX RECEPTACLE COVER, NEMA 3R, CAST WHALE IN USE COVER	
1	1	LEVITON 88991	GROUND FAULT RECEPTACLE, DUPLEX, 20 AMP	
33	2	BUSSMANN FNM-3	FUSE, 3 AMP, 250 V, TIME DELAY TYPE	
34	2	SQUARE D 00U 140	CIRCUIT BREAKER, 1 POLE, 40 AMP, 125 VOLT	
35	1	SQUARE D PK7GTA	GROUND BAR	
36	2	IECC 9H48-LLAC120	CONTROL RELAY, 4PDT, BLADES, INDICATING LIGHT, 120V COIL, 11 PINS	
2	2	IECC 9H48-05	RELAY SOCKET, DIN RAIL MOUNT, 11 PINS	
37	A/R	IECC 9HKN1000	DNRAL, ALUMINUM, 39.37 INCHES	

\* ENGINEER TO SPECIFY BASED ON PUMP STATION REQUIREMENTS

Q (FROM SHEET 2 OF 4)

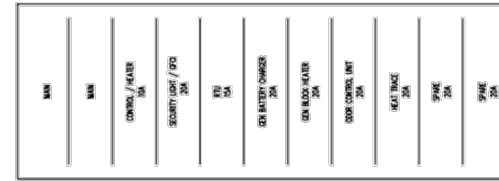

ENGRAVING SCHEDULE							
ID NO.	QTY.	TYPE	SIZE	PLATE COLOR	LETTER COLOR	FIRST LINE	SECOND LINE, ETC.
A	1	N P	1-1/2" X 6"	WHITE	BLACK		\ PUMP STATION \ + VOLT, #HP
B	2	N P	1" X 3"	WHITE	BLACK		PUMP NO. 1
C	2	N P	1" X 3"	WHITE	BLACK		PUMP NO. 2
D	1	N P	1" X 3"	WHITE	BLACK		ALARM CONTROL
E	1	N P	1" X 2"	WHITE	BLACK		CONTROL \ CIRCUIT
F	2	L P	2-1/4" SQ.	WHITE	BLACK		RUNNING
G	2	L P	2-1/4" SQ.	WHITE	BLACK		STOPPED
H	2	L P	2-1/4" SQ.	WHITE	BLACK		PUMP FAILURE
J	2	L P	2-1/4" SQ.	WHITE	BLACK		HAND OFF AUTO
K	1	L P	2-1/4" SQ.	WHITE	BLACK		LIGHT RESET LIGHT/HORN
L	1	L P	2-1/4" SQ.	WHITE	BLACK		HIGH \ LEVEL
M	1	N P	1" X 3"	WHITE	BLACK		PUMP NO. 1 \ OL RESET
N	1	N P	1" X 3"	WHITE	BLACK		PUMP NO. 2 \ OL RESET
O	2	L P	2-1/4" SQ.	WHITE	BLACK		SEAL \ FAILURE
P	1	N P	1" X 3"	WHITE	BLACK		10KVA \ TRANSFORMER
Q	1	N P	3" X 4-3/4"	WHITE	BLACK		(NOTE: SEE DETAIL "A")

NOTE:  
NAMETAGS ATTACHED WITH STAINLESS STEEL SCREWS

LABEL SCHEDULE				
TAG	QTY.	TEXT		
LBL1	1	* VOLT		
LBL2	1	(REVERSE CUSTOM LABEL) TWO * HP MOTOR, * FLA EA. * VAC, * PHASE, 60 HZ * VAC, CONTROL VOLTAGE 120 VAC FILE NUMBER ERR004		
LBL3	1	RECOMMENDED TORQUE \ 5.31-7.09 N. LB.		
LBL4	2	USE COPPER CONDUCTORS ONLY RATED AT 60C OR HIGHER		
LBL5	1	NEMA TYPE 4K, ENCLOSURE RATING		
LBL6	2	TO MAINTAIN ENCLOSURE RATING, USE WATERTIGHT HUBS OR FITTINGS WITH THE SAME ENVIRONMENTAL RATING AS THE ENCLOSURE. O-2/JEJENEY OSM SERIES HUBS APPLETON HUB SERIES HUBS CROUSE-HINDS STG SERIES HUBS		
LBL7	1	DANGER HIGH VOLTAGE		
LBL8	1	CAUTION \ THIS EQUIPMENT \ IS SUPPLIED BY \ MORE THAN ONE \ POWER SOURCE.		
LBL9	1	FUSE SCHEDULE TO REDUCE RISK OF FIRE, REPLACE WITH SAME TYPE AND SIZE FUSES.		
		NO.	MANUF.	TYPE
		214FU	BUSSMANN	FNO-R
		250FU	BUSSMANN	FNM
				AMP
				VOLTS
				1
				600
				2
				250

NOTE:  
1. ASSEMBLED CONTROL PANEL TO BEAR UL 508A LABEL  
2. 10 KVA TRANSFORMER ONLY REQUIRED IF UTILITY VOLTAGE IS 240/480 PRIMARY

FULL VOLTAGE MOTOR STARTER TABLE			
MOTOR HP	208 V SIZE	240 V SIZE	480 V SIZE
2	1	1	1
5	1	1	1
10	2	2	1
15	3	2	2
20	3	3	2
30	4	3	3
40	4	4	3
50	5	4	3

1-50 HP PUMP STATION  
ELECTRICAL DIAGRAMS



BRUNSWICK REGIONAL  
WATER AND SEWER H2GO

EFFECTIVE: OCTOBER 2022

PUMP STATION ELECTRICAL  
BILL OF MATERIALS

STD. NO.

3000.21

NOT TO SCALE